

DAIKIN McQUAY®



Rebel™
Commercial Packaged Rooftop Systems

Catalog 256-1

Heating & Cooling
Models DPS 006 – 012
6 to 12 Tons
R-410A Refrigerant



Engineered for flexibility and performance™

Table of Contents

Introduction	3	Fan Operating Range	19
Features and Options	4	Indoor Fan and Motor Heat	19
Cabinet, Casing, and Frame	4	Altitude Adjustments	19
Compressor	4	Condenser Performance	19
Outdoor Coil	5	Furnace Performance	19
Indoor Coil	5	Condensate Drainage	20
Heatpump Heating	5	Zone Sensor Placement	20
Supply Fan	6	Unit Wiring	20
Variable Air Volume Control	6	Winter Shipment	20
Exhaust Fan	6	Coil Freeze Protection	20
Heating Section	7	Physical Data	21
Filters	8	Performance Data	23
Outdoor/Return Air Section	9	Fan Curves	23
Electrical	9	Heating Capacities	25
Optional Modulating Hot Gas Reheat	12	Air Pressure Drops	26
Modulating Hot Gas Reheat	12	Dimensional Data	27
Application Considerations	14	Electrical Data	35
Acoustical Considerations	17	Engineering Specifications	36
Ductwork Considerations	17	Part 1: General	36
Smoke and Fire Protection	18	Part 2: Products	36
Variable Air Volume Application	18		
Single Zone Variable Air Volume Application	18		

Figure 1: Nomenclature

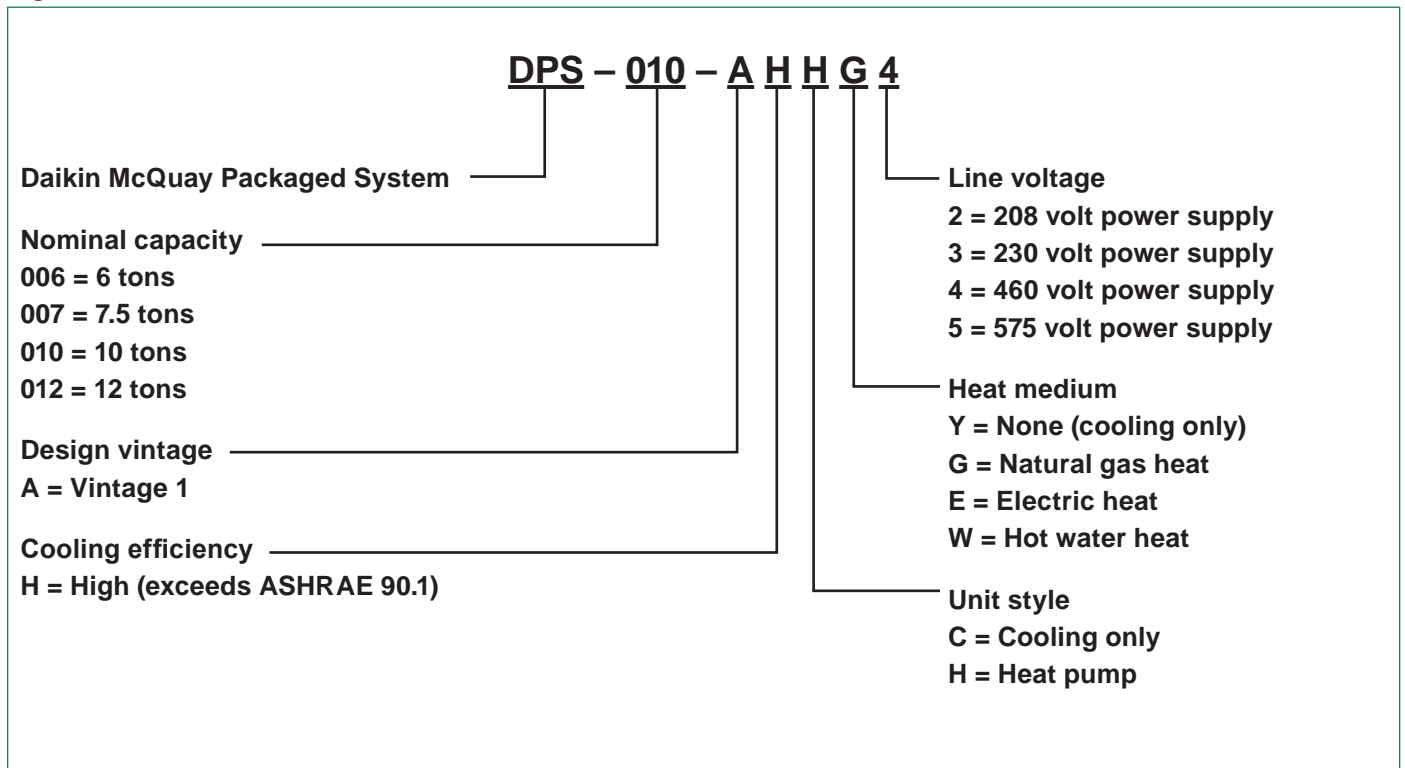

Rebel the most energy efficient packaged rooftop unit

New Daikin McQuay Rebel™ commercial rooftop systems provide building owners with energy savings of 60-70% above ASHRAE's 90.1 standard, enabling for complete system payback in under two years. Combining quality manufactured McQuay equipment with advanced Daikin technologies, Rebel delivers an industry-best commercial rooftop part-load rating of up to 19.5 IEER, making these units ideal for any low-rise commercial building like schools, retail, medical offices, and dedicated outdoor air systems.

Rebel's innovative design utilizes an industry first variable speed Daikin heat pump with hybrid heat (gas, electric, or hot water) options, variable speed ECM motors on all fans, ultra-quiet composite condenser fans, and an advanced modulating variable speed inverter scroll compressor to achieve unprecedented rooftop energy efficiencies.

Configurable as an industry-first VAV heat pump, Rebel offers further configuration flexibility for adverse weather conditions. For much of winter, Rebel's heat pump provides a more economical solution than gas heat. During extreme cold weather, back-up hybrid heat options can be used for additional heat and defrost operation.

Variable speed ECM motors on all fans greatly increase system reliability and efficiency by eliminating use of belts. These motors incorporate built-in inverters and ultra-efficient magnetic rotors to save energy at light load conditions.

Composite Daikin condenser fans create ultra-quiet operation, are UV and corrosion resistant, and deliver tremendous energy savings via ECM motors.

Rebel's variable speed Daikin inverter scroll compressor delivers higher energy efficiency ratios and lower energy costs than typical fixed speed, digital scroll, or 2-stage scroll compressors. The Daikin inverter scroll compressor provides true modulating capacity and unsurpassed comfort control by continuously monitoring and adjusting that temperature. Because the inverter operates and adjusts room temperature only when needed, energy consumption (and noise) drops drastically compared to traditional on/off compressor systems.

Modulating hot gas reheat, electronic expansion valves, economizer, MicroTech® III controls, 100% OA, and more, further contribute to superior efficiencies, enhanced comfort, quiet operation, quality, reliability, and serviceability you expect from the world's leading HVAC manufacturer.

Agency Listed:



Features and Options

Daikin McQuay Rebel rooftop units are built to perform, with features and options that provide for lower installed and operating costs, superior indoor air quality, quiet operation and longevity.

Cabinet, Casing, and Frame

Unit Panel construction includes double-wall with galvanized steel liner to enhance performance and satisfy IAQ requirements.

Figure 2: Durable, Double wall Construction



- Heavy-duty lifting brackets are strategically placed for balanced cable or chain hook lifting.
- Insulated floor panels have a solid galvanized steel inner liner on the air stream side of the unit to protect insulation during service and maintenance.
- 1" thick 2 part injected foam insulation have an R-value of 7.0 for long equipment life and better acoustics.
- Panel design includes no exposed insulation edges.
- Unit cabinet can operate at total static pressures up to 5.0 inches of water.
- Pre-painted galvanized steel exterior surfaces withstand a minimum 750-hour salt spray as per ASTM B117 provides unit for long term durability.
- Access doors include multiple, stainless steel hinges and ¼ turn latch system for easy access.
- The unit base overhangs the roof curb for positive water runoff and seats on the roof curb gasket to provide a positive, weather tight seal.

Compressor

High performance, low noise inverter scroll compressors, adjust the speed to match required total cooling and heating load for efficient part load control.

Figure 3: Inverter Scroll Compressor Technology

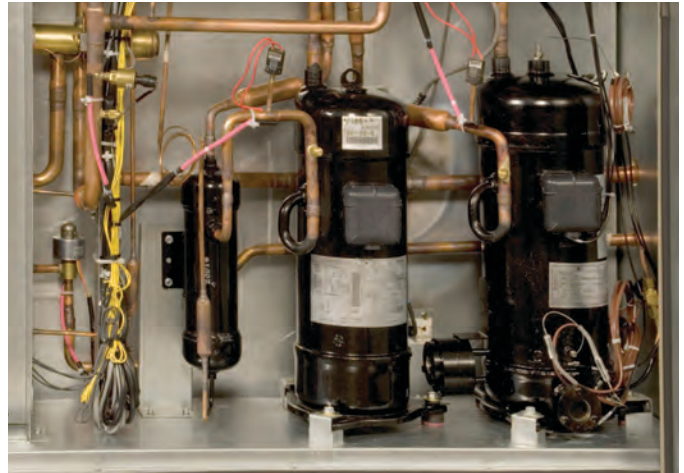

- The inverter scroll compressor has neodymium magnets instead of the typical ferrite magnet for high torque and maximum efficiency. At complete stop of the compressor, the neodymium magnets will position the rotor into the optimum position for a low torque start.
- Refrigeration circuit includes both a low and high pressure transducer, high pressure safety switch and temperature sensors for the suction and discharge. All of the above devices are input to the unit controller and the values be displayed at the unit controller. Crankcase heaters and external thermal overload protection are also provided for compressor durability.
- Refrigerant circuit includes a bypass valve between the suction and discharge refrigerant lines for low head pressure compressor starting and increased compressor reliability.
- Unit is factory charged with environmental friendly and sustainable R-410A refrigerant.
- Oil separators are standard with the equipment along with an intelligent oil management system.
- The compressor is mounted on isolators for quieter operation.

Outdoor Coil

Large face area outdoor coils, with integral sub-cooling circuit, are constructed with seamless copper tubes, mechanically bonded into aluminum plate-type fins with full drawn collars to completely cover the tubes for high operating efficiencies.

Figure 4: Flexible Outdoor Coils Designed for Heat Pump or Cooling Only Operation

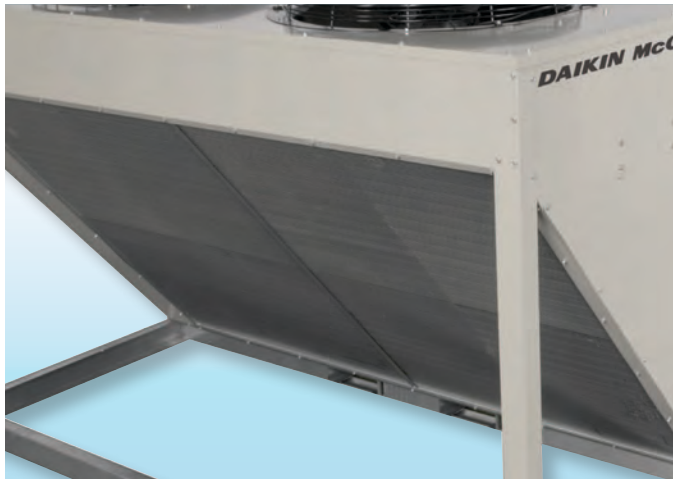

- Each outdoor air coil is factory leak tested with high-pressure air under water for reliable operation.
- Units are shipped with full operating charge of R-410A for quick start up.
- The condensing unit consists of one or more direct drive condenser fans with low noise, patented profile blade design for quieter operation.
- Fan motors have an ECM type motor for proportional control to make sure the space condition are met at ambient condition of 0~125°F.
- A PVC coated, cross-welded, steel wire, coil guard is offered to provide protection for outdoor coil fins as an option.
- Thermal overload and phase failure protection are provided for dependable and long lasting motor operation.
- The fan motor, include permanently lubricated bearings to reduce maintenance cost.
- Sloped condenser coil design provides better hail protection for durability and reliable performance.

Indoor Coil

Indoor coil section is installed in a draw through configuration to provide better dehumidification.

- Direct expansion cooling coils are fabricated of seamless rifflled copper tubing that is mechanically expanded into enhanced aluminum plate fins for high efficiency.
- Multi-row, staggered tube design coils with a minimum of 3 rows allow unbeatable part load and full load efficiencies.
- Cooling coil includes an electronic controlled expansion valve to maintain the liquid sub-cooling and the superheat of the refrigerant system for extreme ambient conditions.
- Each indoor air coil is factory leak tested with high-pressure air under water and completely piped and charged for quick start up and reliable operation.
- Cooling coil is mounted in a stainless steel and positively sloped, ASHRAE 62.1 compliant, double sloped drain pan to improve IAQ.

Figure 5: Rebel Indoor Coil Section

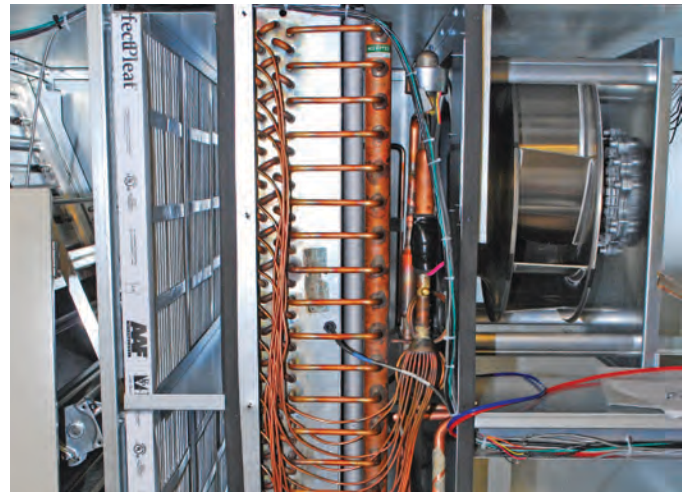

Heatpump Heating

Evaporator coil, condenser coil, compressors and refrigerant circuit are designed for heatpump operation.

- The refrigerant circuit contains a 4 way reversing valve to provide heat.
- The outdoor coil includes an electronic controlled expansion valve to control the refrigerant flow during heat pump operation.
- The unit controller modulates the expansion valve to maintain compressor operation within the compressor operational envelope.
- Hybrid heating option is provided for auxiliary.
- The refrigerant system includes a pump-down cycle for durable operation.

Features and Options

Modulating Hot Gas Reheat

All aluminum fully modulating hot gas reheat coil is provided for dehumidification control.

- Hot gas reheat coil includes aluminum tube micro channel design with high efficiency brazed aluminum fins for direct bonding and provides better heat transfer.
- Modulating reheat coil provides precise temperature and humidity control to maintain required space conditions and reduces the chances of mold growth, sick building syndrome
- MicroTech III integrated controls with compressor and reheat coil energizes whenever dehumidification is needed without using additional energy
- Each indoor air coil is factory leak tested with high-pressure air under water and completely piped and charged for quick start up and reliable operation.

Supply Fan

The airfoil single width, single inlet (SWSI) Class II construction supply fan with aluminum fan blades provides efficient and quiet operation at wide ranging static pressure and air flow requirements.

- Fan wheel is continuously welded to the hub plate and end rim for long lasting reliable operation.
- Direct drive fan with no belts, sheaves, or bearings and permanently lubricated motors provides low maintenance cost.
- A slide out fan assembly provides better serviceability and reduces maintenance time
- Each fan assembly is dynamically trim balanced at the factory before shipment for quick start up and efficient operation.
- MicroTech III integrated controls modulate the totally enclosed EC premium efficiency motor for efficient part load control
- Motor with thermal overload and phase failure protection is provided for motor long lasting operation.

Variable Air Volume Control

MicroTech III proportionally controls the ECM motors on the supply and exhaust fans not only reduces fan energy and operating cost at part load conditions but also improves sound levels.

- Integrated DDC control offers advanced duct and building static pressure control and equipment diagnostics capability.
- ECM fan motor speed is controlled by the unit controller based on space temperature to provide superior space comfort and energy savings for singlezone VAV.
- ECM fan motor speed is controlled by the unit controller based on a duct static pressure sensor to provide superior space comfort.

Exhaust Fan

Single width, single inlet (SWSI) Class II airfoil fans with aluminum blades provide efficient and quiet operation at wide ranging static pressure and air flow requirements.

- Fan wheel is continuously welded to the hub plate and end rim for long lasting, reliable operation.
- Direct drive fan with no belts, sheaves, or bearings and permanently lubricated motors provides low maintenance cost.
- A slide out fan assembly provides better serviceability and reduces maintenance time
- Each fan assembly is dynamically trim balanced at the factory before shipment for quick start up and efficient operation.
- MicroTech III integrated controls modulate the totally enclosed EC premium efficiency motor for efficient part load control
- Motor with thermal overload and phase failure protection is are provided for motor long lasting operation.

Heating Section

Wide ranging natural gas, electric, hot water heat selections effectively handle almost any heating demand from morning warm-up control to full heat.

Figure 6: Gas Furnace

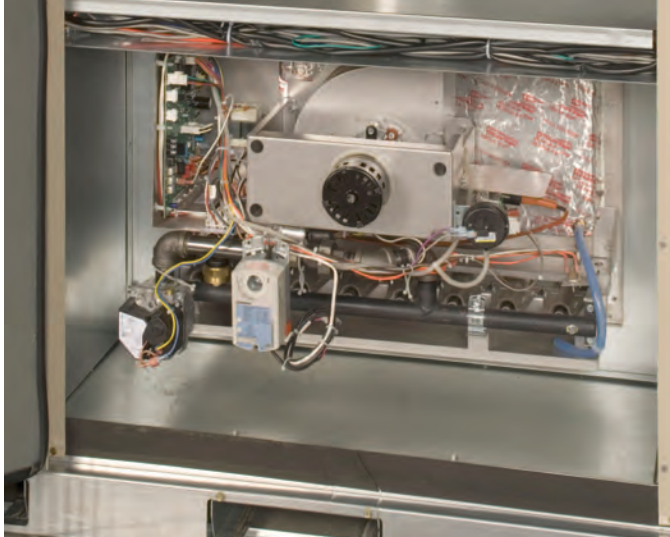

Gas Furnace

ETL certified heating modules from 80 to 400 MBH input provide a custom match to specific design requirement.

- Two stages, 5:1 or 10:1 modulating heating control provides the flexibility to solve diverse needs.
- User has the flexibility to order heat exchanger tubes with 20 Gauge, G160, aluminized steel or stainless steel to meet your application needs.
- The furnace has a tubular design with in-shot gas burner manifold and is installed downstream of the supply fan.
- The module contains an induced draft fan that will maintain a negative pressure in the heat exchanger tubes for the removal of the flue gases to protect indoor air quality
- Each burner module provides flame roll-out safety protection switches and a high temperature limit switch for reliable operation.
- Induced draft fan includes an airflow safety switch to prevent heating operation in the event of no airflow for occupant safety.
- All burner assemblies are factory tested and adjusted prior to shipment.
- Heating control is fully integrated into the unit's MicroTech III control system for quick startup and reliable control.
- Optional field installed LP kits are available for staged heating modules

Figure 7: Electric Heat Coils

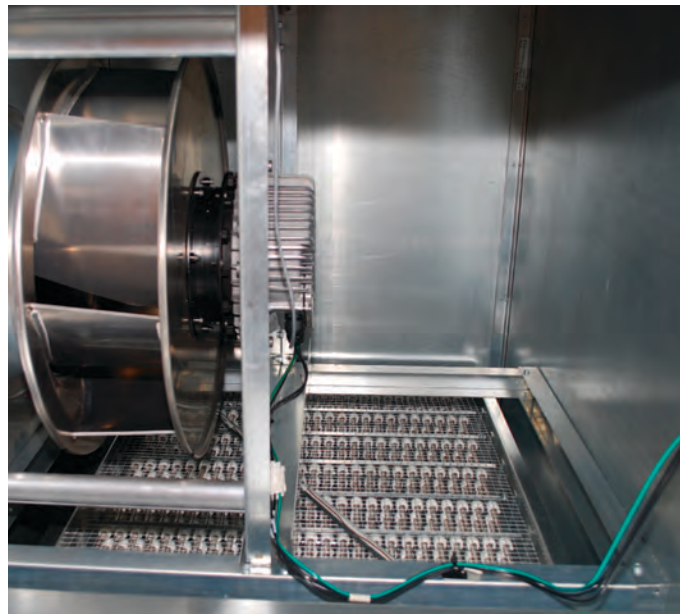

Features and Options

Electric Heat

ETL approved 8 kW to 72 kW electric heat is factory assembled, installed and tested.

- Heating control is fully integrated into the unit's MicroTech III control system for quick startup and reliable control.
- Multi-stage or SCR capability for application flexibility.
- Durable low watt density, nickel chromium elements provide longer life.
- Fuses are provided in each branch circuit to a maximum of 48 Amps per NEC requirements.
- Single point power connection reduces installation cost.
- For operational safeties electric heat includes automatic reset, and high temperature limit safety protection and an airflow safety switch to prevent electric heat operation in the event of no airflow.

Hot Water Coil

1 and 2-row, low and high output options.

- Fully cased coil for better serviceability.
- Factory installed coil vent and drain.
- Piping vestibule for field installed piping control package.
- Unit DDC control provides freeze protection and remote alarm signal.
- DDC control ready with 2–10 volt wiring harness for field supplied and installed valve.
- Each indoor air coil is factory leak tested with high-pressure air under water for reliable operation.

Filters

Unit provides a draw-through filter section

- Both 2" – 4" filter tracks are provided to accept a 2" pre filter and a 4" after filter.
- The filter section includes hinged access door equipped with ¼ turn latch for easy access

Figure 8: Easy Access Filters



Outdoor/Return Air Section

Rebel units are available with a 0% to 30% outdoor air damper or a 0% to 100% economizer or also a 100% outdoor air option.

- Outside air intake hood constructed from painted galvanized steel for longer equipment life.
- Outside air hood includes moisture eliminator filters to prevent water from entering the unit for better IAQ.
- Vinyl gasketed, motorized blade dampers provides efficient operation by reducing leakage during off cycles.
- 0% to 30% damper is field adjusted to a fixed open position that is easily set using the MicroTech III keypad, allowing for a balance between IAQ and energy savings.
- 0% to 100% option includes outside and return air dampers sized to handle 100% of the supply air volume for efficient and reliable operation.
- 0% to 100%, fully functional, modulating economizer provides free cooling and reduces compressor energy and operating cost
- Economizer control is fully integrated into the unit's MicroTech III control system and features a spring-return actuator, adjustable minimum outside air set point and adjustable changeover.
- Dry bulb or comparative enthalpy economizer changeover control is available to provide the most economical amount of outside air for "free" cooling.
- Barometric relief dampers are standard for exhaust control and exhaust air out of the back of the unit and also include bird screen to prevent infiltration.

Electrical

Units are completely wired and tested at the factory to provide faster commissioning and start-up.

- Wiring complies with NEC requirements and all applicable UL standards.
- For ease of use, wiring and electrical components are number coded and labeled according to the electrical diagram.
- A 115 V GFI convenience receptacle requiring independent power supply for the receptacle is standard.
- An optional unit powered 20 amp 115 V convenience receptacle, complete with factory mounted transformer, disconnect switch, and primary and secondary overload protection, eliminates the need to pull a separate 115 V power source.
- Supply air fan, compressor, and condenser fan motor branch circuits have individual short circuit protection. Unit includes knockouts in the bottom of the main control panels for field wiring entrance.
- A single point power connection with power block is standard and a terminal board is provided for connecting low voltage control wiring.
- 115-volt control circuit transformer and fuse, system switches, and a high temperature sensor are for provided with the unit.
- For better serviceability an optional non-fused disconnect switch is optionally mounted inside the control panel and operated by an externally mounted handle for disconnecting electrical power at the unit.

Features and Options

Rebel™ Packaged Singlezone Heating and Cooling Units—6 to 12 Tons



1 Variable speed Daikin inverter compressor

- Modulating capacity allows for optimum comfort control
- Best part-load efficiency in the industry
- Dependable and quiet operation
- Superior discharge air temperature control

2 Variable speed Daikin heat pump

- More economic than gas heat during winter
- Hybrid backup heat options for extreme cold weather and defrost operation
- Modulating capacity delivers the industry's best heat pump control

3 Electronic expansion valves

- Optimum control of superheat
- Protects compressor from liquid refrigerant
- Increases efficiency by safely lowering head pressure

4 MicroTech® III unit controller

- Open Choices™ feature provides interoperability with BACnet®, Daikin D3 and LonWORKS® communication options for easy integration with building automation systems
- Unit diagnostics for easy serviceability
- Outdoor air and humidity control logic maintains minimum fresh air intake and optimum humidity levels

5 Seamless top panel

- Seamless construction prohibits leaks

6 Hinged access doors

- ¼–turn latch door provide easy access to system components for maintenance and service

7 Full-perimeter, forkable base rail

- Allows easy maneuvering and installation

8 Variable speed ECM motors on all fans

- Greatly increases system reliability and efficiency eliminates belts and bearing setscrews
- Saves energy at light load
- Super-efficient magnetic rotor
- Built-in inverter eliminates control panel heat

9 Hybrid backup heat options

- Gas furnace with turndowns as high as 10.1
- Electric heat option with SCR for precise temperature control
- Hot water heat

Rebel™ Packaged Singlezone Heating and Cooling Units—6 to 12 Tons Features and Options

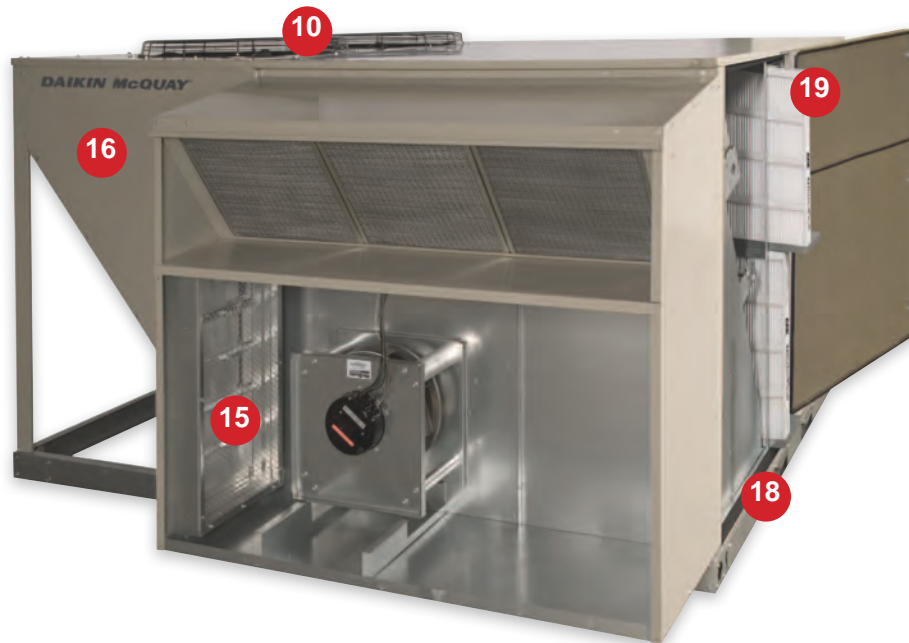

10 Ultra-quiet Daikin condenser fans

- One-piece composite blade design for noiseless operation
- UV and corrosion resistant
- Variable speed ECM motors provide tremendous energy savings at lower ambient

11 Double-wall foam cabinet

- No exposed insulation to the air stream
- Better thermal seal than fiberglass

12 Dehumidification Control

- Hot gas used for “free” reheat
- Tight humidity control without over cooling the space
- Modulating hot gas reheat coil

13 Stainless steel, double sloped drain pan

- Prevents corrosion
- Avoids standing water for high IAQ

15 100% outdoor air option

- Low-leak dampers
- Double-wall blades, edge and jam seals
- Modulating 100° temperature rise furnace
- Modulating compressor
- Modulating hot gas reheat

16 Durable construction

- Foam-injected panels with an R-value of 7
- Increased insulation value for increased system efficiency
- Double-wall construction for increased indoor air quality

17 Low radiated noise

- Enclosed compressor
- Quiet outdoor fan
- Excellent acoustics at lower speeds

18 Economizer

- Provides free-cooling when outdoor conditions are suitable
- Provides fresh air to meet local requirements
- Integrated economizer operating with mechanical cooling
- Optional demand control ventilation for increased system efficiency

19 2" and 4" slide-out filter racks

- Easy filter changeouts for quick serviceability

Optional Modulating Hot Gas Reheat

Modulating Hot Gas Reheat

The reheat coil option comes complete with an aluminum micro-channel coil and modulating hot gas valves for leaving air temperature control.

On a call for dehumidification, the unit will enable the supply side to be over-cooled by the DX coil. Hot gas from the unit condenser will be routed to an indoor coil downstream of the DX coil to reheat the air. Hot gas reheat valves (Figure 9) will control how much hot gas is routed to the indoor coil to maintain a discharge air setpoint.

Figure 9: Dual 2-Way Valve Refrigeration Schematic (Cooling Model Shown)

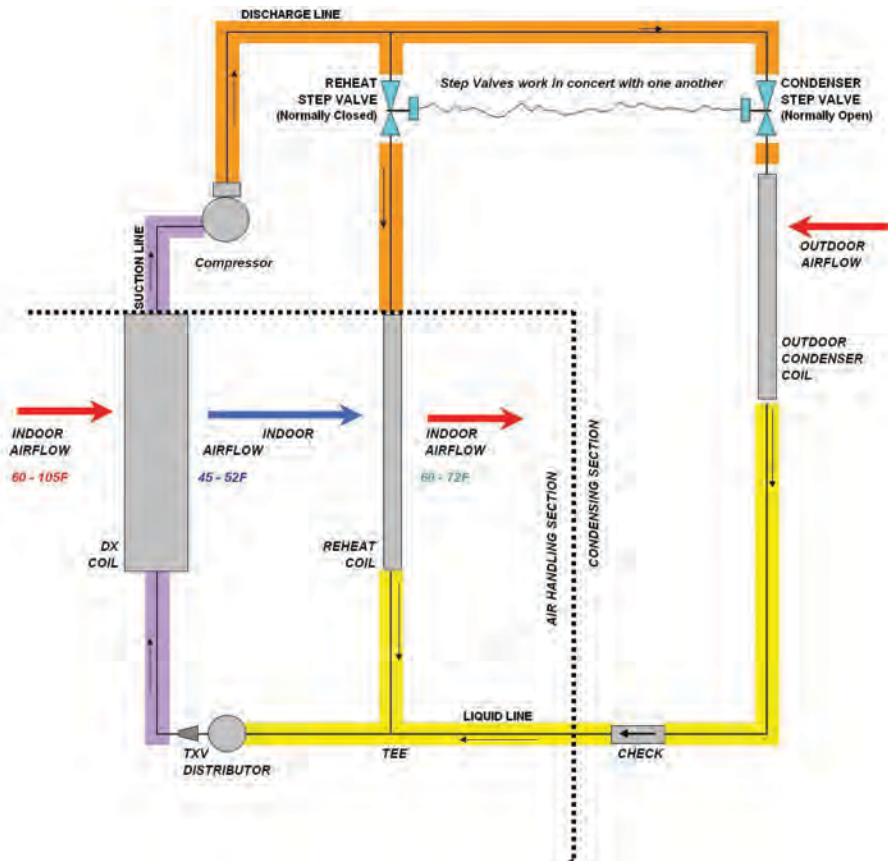
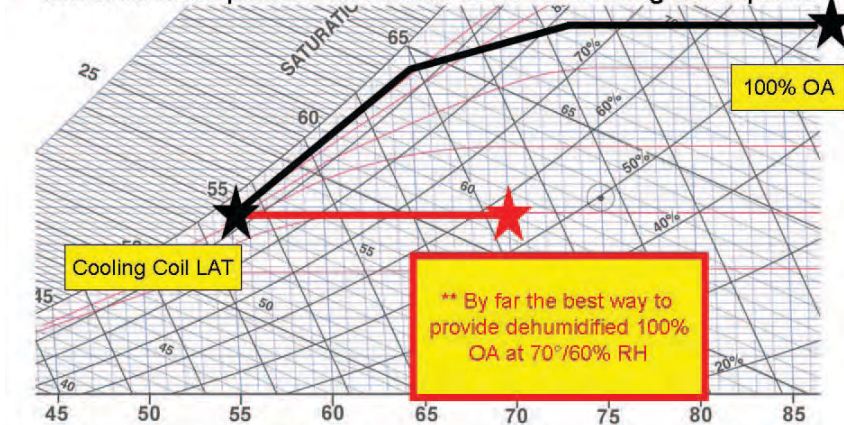

Figure 10: Ideal for Neutral Air Ventilation Control

- The rooftop mainly dehumidifies the required ventilation air
- Terminal units provide additional sensible cooling as required



Dehumidification Initiation

An analog sensor is mounted in the return duct, the space, or outdoors to sense relative humidity. The location is selected by setting the sensor location value on the keypad to return, space, or OAT. OAT can only be selected for units with DAT control. Dehumidification is disabled when the unit is in either the heating or minimum DAT state. When dehumidification is enabled, dehumidification operation is initiated when humidity control is set to either relative humidity or dew point and that value rises above the appropriate setpoint by more than half of its deadband. Economizer operation is disabled in the dehumidification mode so the unit immediately transitions to cooling if dehumidification is initiated in economizer state.

Dehumidification Termination

Dehumidification is terminated if the selected variable, relative humidity or dew point, drops below the appropriate humidity setpoint by more than half its deadband. Dehumidification is also terminated if cooling is disabled for any reason or the unit enters either the heating or minimum DAT state. For units with compressors, the number of cooling stages is reduced by one and control reverts to normal control when dehumidification is terminated in the cooling state. Another compressor stage change could then occur after one cooling stage time has elapsed.

Control & Arrangement

In conjunction with dehumidification, MHGRH is used to raise the temperature of the cooled air to a desirable value. MHGRH is comprised of a parallel coil arrangement, with dual reheat valves (which operate in concert with one another) and a check valve.

During dehumidification control with modulating hot gas reheat (MHGRH), an analog signal (0-10Vdc) is controlled as described below.

- A PI loop is used to control the HGRH valves to maintain the discharge air temperature from the reheat coil.
 - Compressor staging and speed during reheat (or dehumidification) will be controlled by the leaving DX coil temperature. For increased dehumidification during reheat, the standard default compressor staging range is 45 - 52°F.
 - When dehumidification is active in the cooling state, the reheat set point equals the DAT cooling setpoint. For DAT units, this is the normal DAT set point resulting from any reset. For zone control units, this set point is the result of a PI loop based on the control temperature.
 - Communication with the reheat control valves is accomplished by providing a 0-10 Vdc signal to a pair of interface boards which in turn supply the control signal to the reheat valves (step type).
- In the fan only state, no sensible cooling is required, but dehumidification mode will still be enabled if the dew point or humidity sensor is not satisfied. Reheat set point varies from a maximum value (default 65°F) when the control temperature is at or below the heating changeover setpoint to a minimum value (default 55°F) when the control temperature is at or above the cooling changeover setpoint.
 - In the reheat mode, the minimum position for the reheat valves is 10% (1.0 Vdc). The controller will modulate the reheat valves from this starting position.
 - Reheat valve(s) must be at 0% (0 Vdc) position before starting the first compressor in the reheat circuit to prevent pressure spikes.
 - Upon termination of dehumidification (reheat), the maximum ramp down or decay rate of the reheat control valves shall be 1% per sec (or 0.1V per sec).
 - Upon termination of dehumidification (reheat), staging of compressor(s) is delayed for 1 minute after reheat capacity = 0% (0 Vdc).
 - Every 24 hours, the reheat control valves will be driven to their maximum position (10Vdc) and then returned to their normal operating position (0Vdc). If unit is operating in cooling or dehumidification (reheat) at the prescribed time it will be deferred to the next time.
 - Dehumidification status can now be found under the MicroTech III main system menu. Reheat capacity (valve position) can also be found under the main system menu, display based on percentage (0-100%).

Application Considerations

Daikin McQuay Rooftop units are intended for use in normal heating, ventilating, and air conditioning applications. Consult your local Daikin McQuay sales representative for applications involving operations at high ambient temperatures, high altitudes, non-cataloged voltages, or for job specific unit selections that fall outside of the range of the catalog tables.

For proper operation, units should be rigged in accordance with instructions stated in IM 1125. Fire dampers, if required, must be installed in the ductwork according to local and/or state codes. No space is allowed for these dampers in the unit. Follow factory check, test and start procedures explicitly to achieve satisfactory start-up and operation (see IM 1125). Most rooftop applications take advantage of the significant energy savings provided with economizer operation. When an economizer system is used, mechanical refrigeration is typically not required below an ambient temperature of 50°F. Standard DPS refrigeration systems are designed to operate in ambient temperatures down to 0°F.

Unit Location

The structural engineer must verify that the roof has adequate strength and ability to minimize deflection. Take extreme caution when using on a wooden roof structure. Unit condenser coils should be in a location that avoids any heated exhaust air.

Allow sufficient space around the unit for maintenance/service clearance. Refer to [Figure 11](#) for recommended clearances. Consult your Daikin McQuay sales representative if available clearances do not meet minimum recommendations. Where code considerations, such as the NEC, require extended clearances, these take precedence.

Service Clearance

Allow for recommended service clearances as shown in [Figure 11](#). Provide a roof walkway along the sides of the unit for service and access to controls and components. Contact your Daikin McQuay sales representative for service requirements less than those recommended.

Curb Installation

The roof curb is field-assembled and must be installed level (within 1/16" per foot side to side). A sub-base must be constructed by the contractor in applications involving pitched roofs. Gaskets are furnished and must be installed between the unit and curb. For proper installation, follow NRCA guidelines. Typical curb installation is illustrated in [Figure 12](#) and [Figure 13](#).

In applications requiring post and rail installation, an I-beam securely mounted on multiple posts should support the unit on each side. In addition, the insulation on the underside of the unit should be protected from the elements.

Applications in geographic areas subjected to seismic or hurricane conditions must meet code requirements for fastening the unit to the curb and the curb to the building structure.

Figure 11: Service Clearances

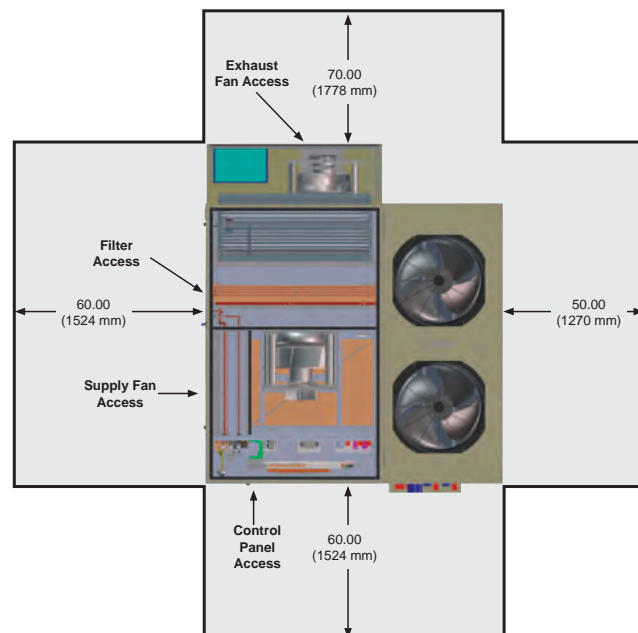

Application Considerations

Figure 12: Roof Curb Assembly (DPS 006)

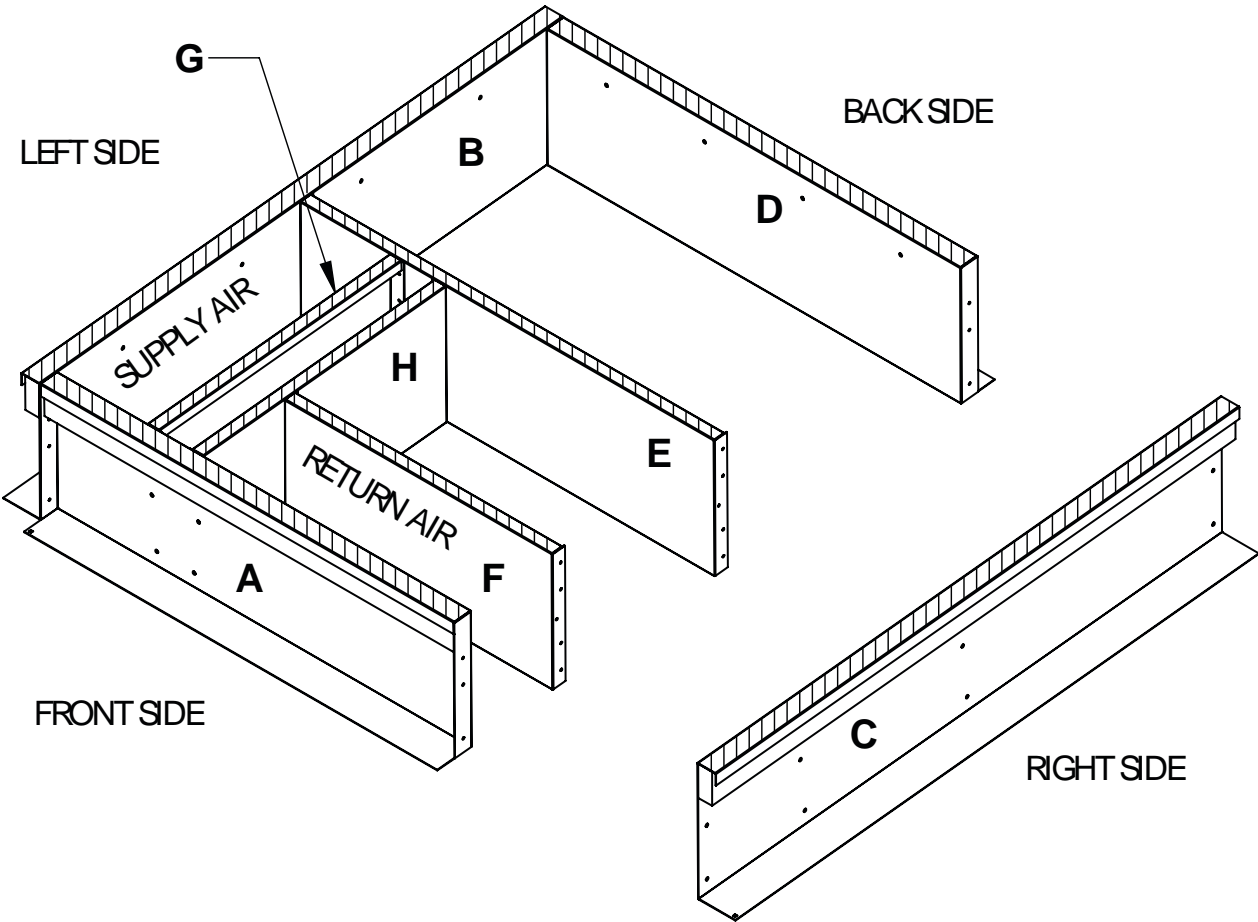

NOTE: 1. Check submittal drawing for gas/water/electrical/supply/return air opening

NOTE: Horizontal above the roof gas connection only

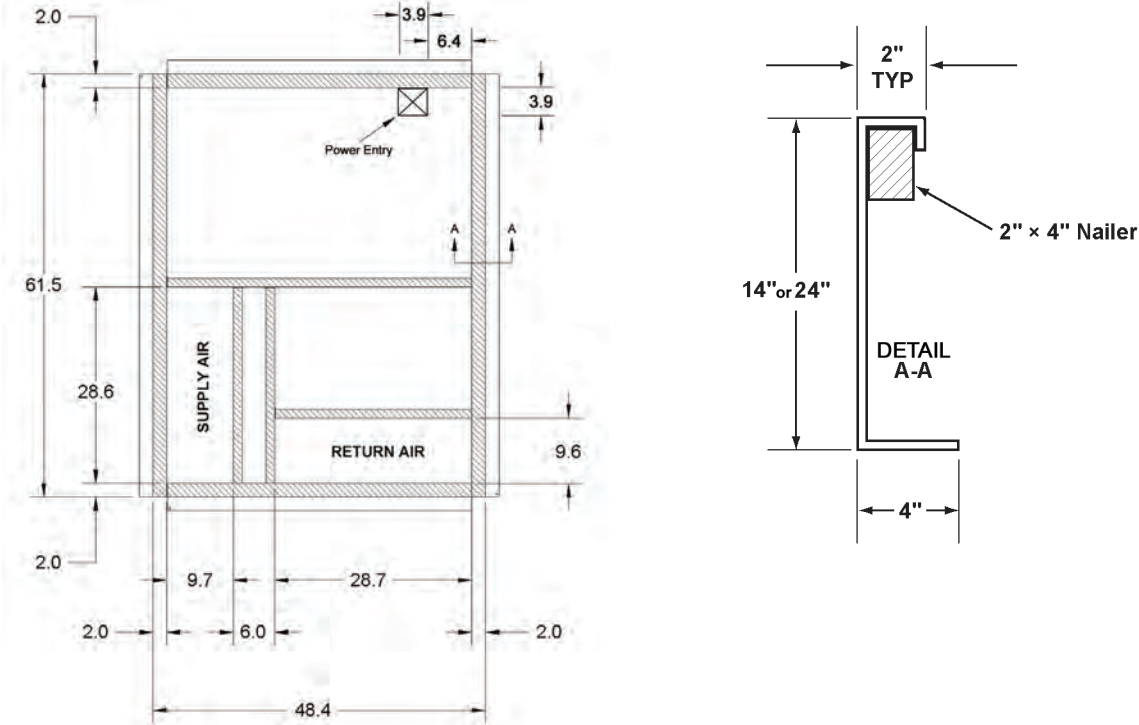

Application Considerations

Figure 13: Roof Curb Assembly (DPS 007-012)¹

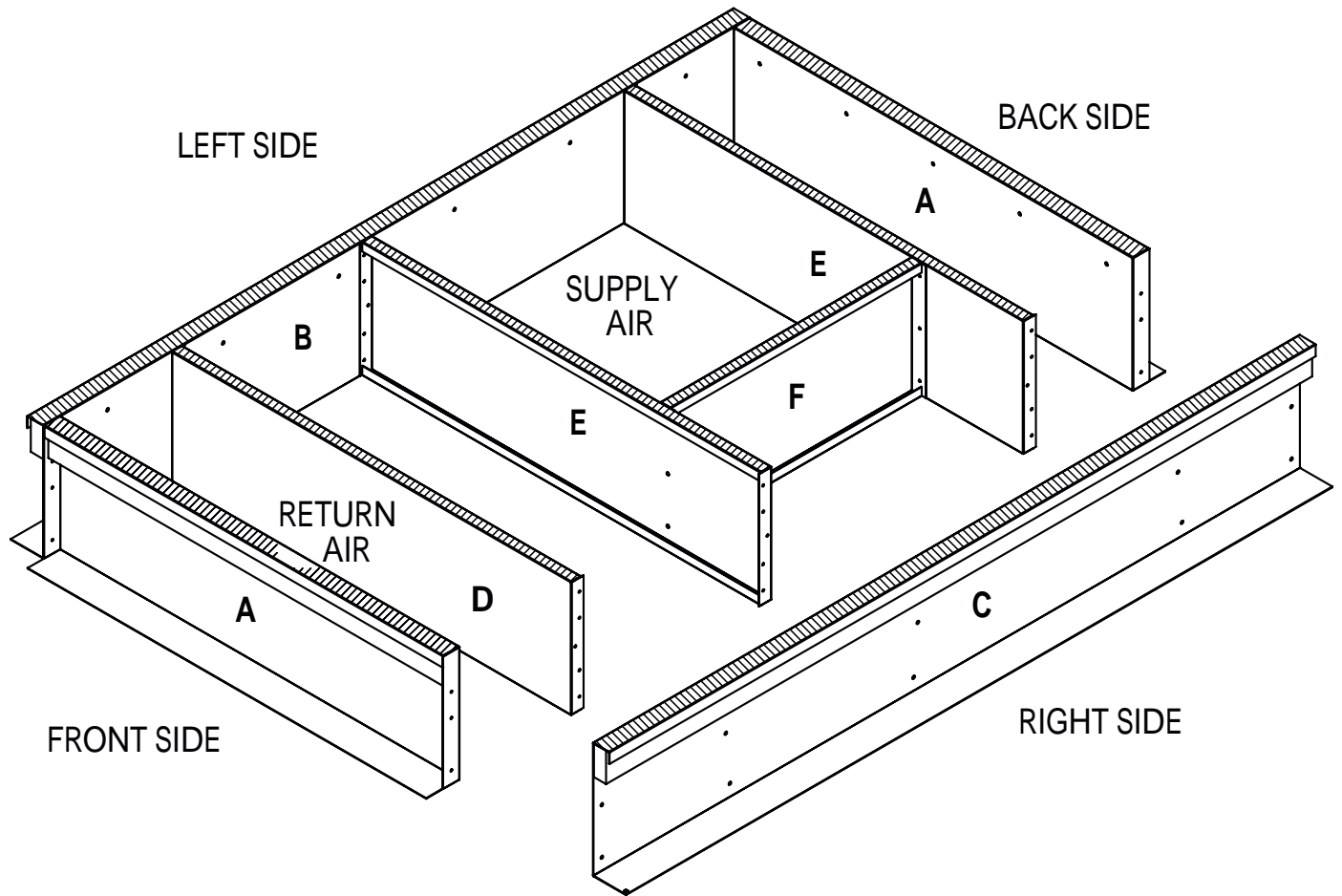

NOTE: 1. Check submittal drawing for gas/water/electrical/supply/return air opening
NOTE: Horizontal above the roof gas connection only

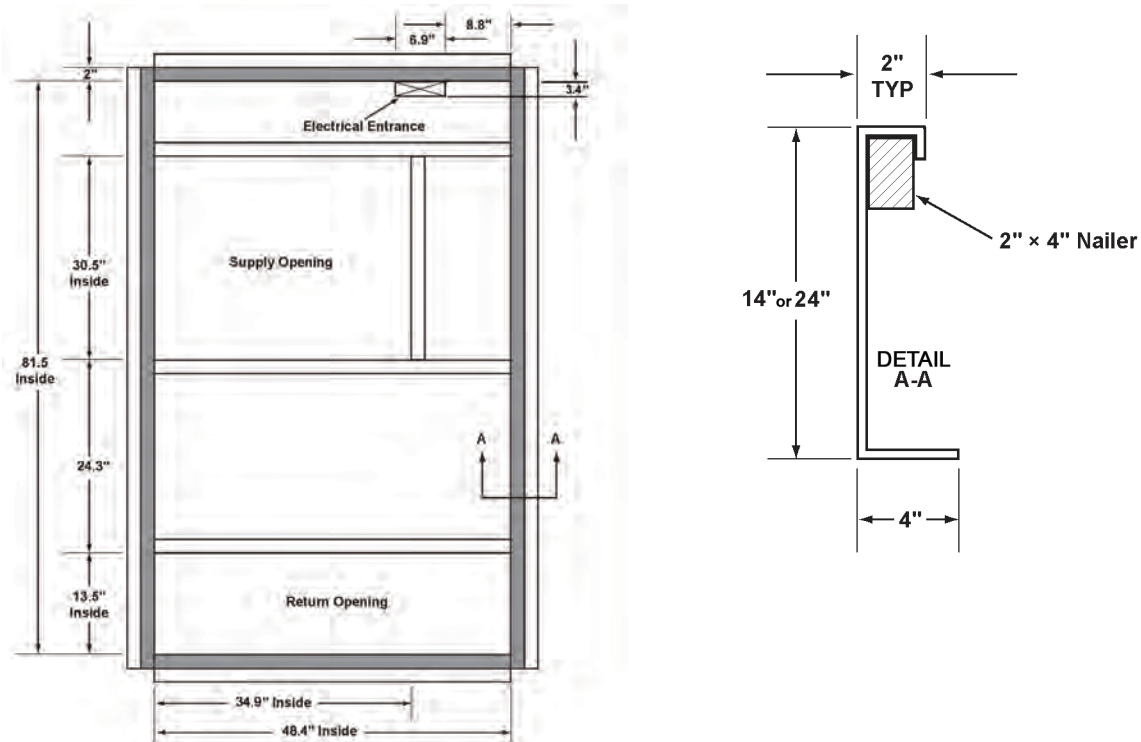

Acoustical Considerations

Good acoustical design is critical for any installation and should start at the earliest stages in the design process. Common sound paths for rooftop equipment must be addressed are:

- Radiated sound through the bottom of the unit (air handling section and condensing section) and into the space.
- Radiated sound to the property line.
- Structure-borne vibration from the unit to the building.
- Airborne sound through the supply air duct.
- Airborne sound through the return air duct.

Locating rooftop equipment away from sound sensitive areas is critical and the most cost effective means of avoiding sound problems. If possible, rooftop equipment should always be located over less sensitive areas such as corridors, toilet facilities or auxiliary spaces and away from office areas, conference rooms and classrooms. Some basic guidelines for good acoustical performance are:

- Provide proper structural support under all areas of the unit.
- Always locate the unit's center of gravity close to a main support to minimize roof deflection.
- Use a concrete deck or pad when a unit has to be located over an occupied space where good acoustics are essential.
- Only the supply and return air ducts should penetrate the acoustical material and decking within the curb perimeter, and the openings must be sealed once the duct is installed.
- Don't overlook the return air path. Never leave a clear "line of sight" into a return or exhaust fan; always include some duct work (acoustically lined tee) at the return inlet.
- Place acoustical material in the area directly beneath the condensing section.
- Select acoustical material that discourages microbial growth.
- Minimize system static pressure losses to reduce fan sound generation.
- Design duct systems to minimize turbulence.
- Account for low frequency duct breakout in system design. Route the first 20 ft. of rectangular duct over non-sensitive areas and avoid large duct aspect ratios. Consider round or oval duct to reduce breakout.

There are many sound sources in rooftop systems. Fans, compressors, condenser fans, duct take-offs, etc., all generate sound. For guidelines on reducing sound generation in the duct system, refer to the ASHRAE Applications Handbook. Contact your local Daikin McQuay sales representative for equipment supply, return and radiated sound power data specific to your application.

Ductwork Considerations

A well-designed duct system is required to allow the rooftop equipment to provide rated performance and to minimize system resistance and sound generation. Duct connections to and from units should allow straight, smooth airflow transitions. Avoid any abrupt change in duct size and sharp turns in the fan discharge. Avoid turns opposed to wheel rotation since they generate air turbulence and result in unwanted sound. If 90° turns are necessary, use turning vanes. Refer to the ASHRAE Applications Handbook for specific guidelines relevant to rooftop equipment.

Return Duct

The return path is the most often overlooked. A section of return duct is required to avoid a "line of sight" to the return air opening and to provide attenuation of return air sound. Install an insulated tee with a maximum duct velocity of 1000 to 1200 feet per minute. Extend the duct 15 feet to provide adequate attenuation.

Supply Duct

Insulate supply air ductwork for at least the first 20 feet from the unit. Consider the use of round or oval ductwork, as it significantly reduces low frequency breakout noise near the equipment. If rectangular duct is used, keep the aspect ratio of the duct as low as possible. The large flat surfaces associated with high aspect ratios increase low frequency breakout to the space and can generate noise, such as "oil canning." The maximum recommended supply duct velocity is 1800 to 2000 feet per minute.

Duct High Limit

A Daikin McQuay Packaged System with VAV control includes a duct high limit switch as a standard feature that is of particular importance when fast acting, normally-closed boxes are used.

Vibration Isolation

Make duct attachments to the unit with a flexible connection. Economizer and Exhaust Fan Application Rooftop economizer applications usually require exhaust fans to properly control building pressure and maintain minimum ventilation. The air balancer must adjust the outdoor air damper to provide minimum ventilation settings. The EAF is normally-off during non-economizer operation. During these minimum outdoor air conditions, the system essentially acts like a supply fan only system.

Application Considerations

Smoke and Fire Protection

Due to the wide variation in building design and ambient operating conditions our units are applied, we do not represent or warrant that our products are fit and sufficient for smoke, fume, and fire control purposes. The owner and a fully qualified building designer are responsible for meeting all local and NFPA building code requirements with respect to smoke, fume, and fire control. The unit's control panel has a terminal block that a supply air and return air smoke detector can be wired to. An optional return air smoke detector is offered. Any other smoke detector, its installation, and the wiring to the unit controller are all field supplied.

Variable Air Volume Application

Rebel units include ECM supply and exhaust fans to provide variable air volume (VAV) control as shown in Figure 14. Daikin McQuay Rebel variable air volume systems (VAV) employ the concept of varying the air quantity to a space at a constant temperature, thereby balancing the heat gains or losses and maintaining the desired room temperature. This ability to reduce supply air quantities not only provides substantial fan energy savings at partial load conditions, but it also minimizes equipment sizing. Variable volume systems offer the following advantages:

- Lower system first cost by using system diversity to reduce equipment and duct sizes.
- Lower operating costs by reducing fan energy demands, especially at part load conditions.
- Provides excellent acoustics at lower air flows.

In placing a duct static pressure sensor, locate a pressure tap near the end of the main duct trunk. Adjust the static pressure setpoint so that at minimum airflow all of the terminals receive the minimum static pressure required plus any downstream resistance. Locate the static pressure sensor tap in the ductwork in an area free from turbulence effects and at least ten duct diameters downstream and several duct diameters upstream from any major interference, including branch takeoffs.

Single Zone Variable Air Volume Application

A unit configured for single zone VAV will use discharge air control for mechanical cooling and heat, with VAV control of the supply air fan based upon the space or return air temperature and will require discharge air control (DAC) on top of standard ECM fan motors. The MicroTech III controller will also use the control temperature to transition between cooling, fan only, and heating modes. Singlezone variable volume systems offer the following advantages:

- Lower system first cost.
- Lower operating costs by reducing fan energy demands, especially at part load conditions.
- Provides excellent acoustics at lower air flows.

Figure 14: Variable Air Volume (VAV) Control

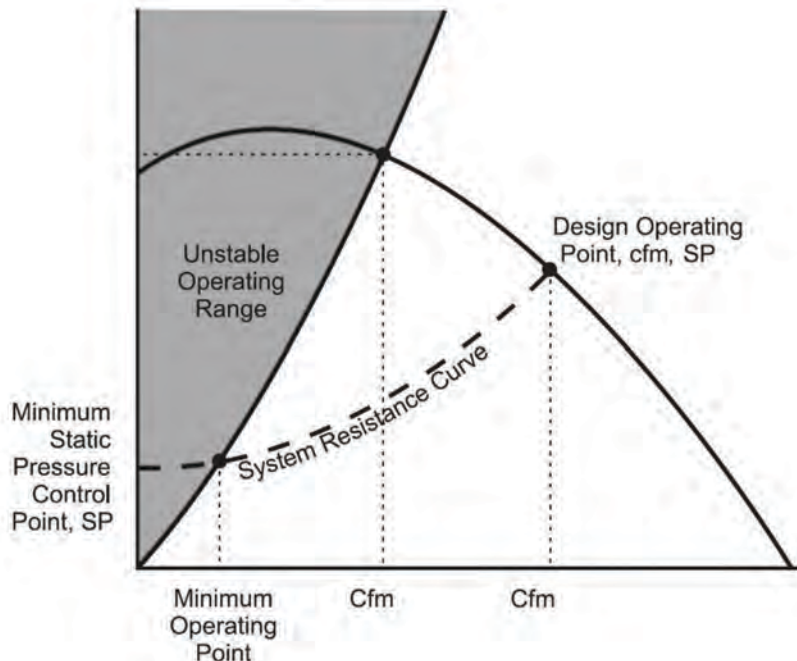

Fan Operating Range

The acceptable system operating range of the Daikin McQuay rooftop is determined by all of the following characteristics. Each of these limiting factors must be considered for proper performance and component design life:

- Unstable fan operation.
- Maximum fan rpm.
- Maximum cabinet static pressure.
- Maximum face velocity (cooling coil is most important).
- Minimum furnace velocity.
- Turndown capability on VAV applications.
- Compressor operating pressures.

Indoor Fan and Motor Heat

The indoor fan and motor electrical consumption is a sensible cooling load approximately equal to 2.8 MBh per bhp (depending slightly on motor efficiency). The fan and motor temperature rise is equal to $Btuh / (1.08 \times cfm)$ and is typically about 3°F.

Altitude Adjustments

Fan Curve Performance

Fan curve performance is based on 70°F air temperature and sea level elevation. Selections at any other conditions require adjustment for air densities listed in [Table 1 on page 19](#). Higher elevations generally require more rpm to provide a given static pressure but less bhp due to the decrease in air density.

Example:

Assume 2,000 cfm is required at 1.00" TSP. The elevation is 5000 ft. and 70°F average air temperature is selected. A 14" SWSI airfoil fan is selected.

1. The density adjustment factor for 5000 ft. and 70°F is 0.83.
2. TSP must be adjusted as follows:
 $1.0" / 0.83 = 1.20"$.
3. Locate 2,000 cfm and 1.2 on the fan curve.
Rpm = 1720 and bhp = 0.53.
4. Consumed fan power at design =
 $0.53 \text{ bhp} \times 0.83 = 0.44 \text{ bhp}$.

Table 1: Temperature and Altitude Conversion Factors

Air temp (°F)	Altitude (feet)								
	0	1000	2000	3000	4000	5000	6000	7000	8000
-20	1.20	1.16	1.12	1.08	1.04	1.00	0.97	0.93	0.89
0	1.15	1.10	1.08	1.02	0.99	0.95	0.92	0.88	0.85
20	1.11	1.06	1.02	0.98	0.95	0.92	0.88	0.85	0.82
40	1.06	1.02	0.98	0.94	0.91	0.88	0.84	0.81	0.78
60	1.02	0.98	0.94	0.91	0.88	0.85	0.81	0.79	0.76
70	1.00	0.96	0.93	0.89	0.86	0.83	0.80	0.77	0.74
80	0.98	0.94	0.91	0.88	0.84	0.81	0.78	0.75	0.72
100	0.94	0.91	0.88	0.84	0.81	0.78	0.75	0.72	0.70
120	0.92	0.88	0.85	0.81	0.78	0.76	0.72	0.70	0.67
140	0.89	0.85	0.82	0.79	0.76	0.73	0.70	0.78	0.65

Condenser Performance

Altitudes greater than sea level require a derate in condenser and cooling performance that can be estimated as follows:

For altitudes up to 6000 feet:

- Cooling capacity decrease factor (all sizes) = 0.5% per 1000 feet.
- Compressor kW increase factor = 0.6% per 1000 feet.

For altitudes above 6000 feet, consult the factory. The actual derate varies with each individual unit and design conditions. Your local Daikin McQuay representative can provide exact performance data.

Furnace Performance

Gas heat performance data is based on standard 70°F air temperature and zero feet altitude (sea level).

For altitudes between 2000 to 6000 feet, the gas burner must be derated 4% for every 1000 feet of altitude.

Example:

A 400 MBh furnace at an altitude of 3000 feet is derated ($0.04 \times 3 = 0.12$). At 400 MBh input (400×0.12 MBh), the actual input is ($400 - 48 = 352$ MBh) at 3000 feet.

For altitudes above 6000 feet, consult the factory.

Application Considerations

System Operating Limits

Daikin McQuay DPS systems are designed to operate over an extensive operating range. However, for proper system operation some limits do apply.

To help prevent moisture blow-off, design guidelines have been established for cooling coil selection. For applications outside of these limits, consult your Daikin McQuay sales representative.

In addition to maximum face velocity limitations, minimum velocity guidelines must also be followed. In order to maintain proper refrigeration performance, the minimum coil face velocity is 175 ft./min. When selecting a variable air volume unit, it is necessary to design the system such that the 175 ft./min. limit is maintained at light load conditions.

Condensate Drainage

Provide all drain pans with a properly sized p-trap to allow free drainage of coil condensate. For trap sizing, follow instruction given in IM 842. Run all traps and drain lines full size from the threaded unit connection to the roof drain.

Zone Sensor Placement

Placement of the zone temperature sensor is critical for proper and economical operation of the heating and cooling system. It is generally recommended that the space sensor be located on an inside wall (3 to 5 feet from an outside wall) in a space having a floor area of at least 400 square feet. Do not locate the sensor below the outlet of a supply diffuser, in the direct rays of the sun, on a wall adjacent to an unheated or abnormally warm room (boiler or incinerator room), or near any heat producing equipment. Where zone sensor placement is a problem, all zone control systems, as standard, have the capability to use a return air sensor for heating and cooling.

Unit Wiring

All units require three phase, 60 Hz, 208, 230, 460, or 575 volt power supply. All units include branch circuits and short circuit protection and are available with a power block or nonfused disconnect switch. Each unit is provided with a 115 V convenience outlet. Per the NEC, this circuit must be fed independent of the main unit power supply.

All wiring must be installed in accordance with the National Electric Code (NEC) and local codes.

Winter Shipment

Flat bed shipment in winter can expose units to harsh road chemicals. Since equipment size and configuration precludes covering during transit, wash units free of these chemicals as soon as possible to help prevent corrosion.

Coil Freeze Protection

When applying roof-mounted equipment in areas that experience subfreezing conditions, coil freeze protection measures must be provided. Subfreezing temperatures can adversely affect water and steam coils during controlled or uncontrolled unit shutdowns and even during unit operation. Daikin McQuay economizer dampers are arranged to direct the outside and return air streams toward each other, however, there may not always be a uniform unit temperature profile under all load and ambient temperatures. Some temperature stratification will occur, particularly at low ambient temperatures and the associated reduced airflow inherent with VAV systems.

Glycol is strongly recommended as a positive means of freeze protection for water coils. No control sequence can prevent coil freezing in the event of a power failure or equipment malfunction. During those periods, glycol is the only positive means of freeze protection. When selecting water coils, specify glycol to account for performance differences.

Figure 15: Physical Data—Standard Units DPS 006 through 012

Model	Small Cabinet		Large Cabinet	
	006	007	010	012
Cooling only performance				
Gross Cooling capacity (tons)	6	7.5	10	12
Nominal airflow (cfm)	2400	2650	3500	4200
EER ¹	11.6	12.6	12.5	12.1
IEER ¹	19.2	18.7	17.9	18.5
Heat pump performance				
High Temperature Capacity @ 47°F (MBh)	71	88	118	138
COP @ 47°F	4.1	4.27	3.84	3.60
Low Temperature Capacity @ 17°F (MBh)	40	53	71	82
COP @ 17°F	2.75	2.90	2.67	2.50
Electric heat performance				
Control Options	2/4/SCR		4 stage/SCR	
kW (low/medium/high heat)	6/12/18/30		18/36/54/72	
Gas heating performance				
Input capacity (MBh)	80/120/160		200/300/400	
Number of stages (staged option)	2			
Turndown (Modulating options)	5:1		5:1, 10:1	
Gas connection size (mpt)	1/2"		3/4"	
Steady state efficiency	80%			
Heating coil				
Type	Hot Water			
Rows / FPI (high heat/low heat)	(2/10) / (1/8)			
Face area (sq ft)	2.5		5.4	
Compressors				
Quantity / Type	(1) Inverter Scroll		(1) Inverter Scroll, (1) Fixed Speed Scroll	
Number of stages	Modulating			
Refrigerant	R-410A			
Indoor coil				
Rows / FPI	4/16	3/15	4/15	4/15
Face area (sq ft)	6.0	14	15.4	15.4
Capacity control	Electronic Expansion Valve (EEV)			
Outdoor coil				
Type	Copper tube			
Rows / FPI	3 / 16	3 / 16	4 / 16	4 / 16
Indoor fan				
Type	Centrifugal Airfoil (SWSI)			
Quantity / Diameter ²	(1) 12", (1) 14", (1) 16"	(1) 14", (1) 16", (1) 22"	(1) 22"	
Quantity / Diameter ³	(1) 12", (1) 14", (1) 16"	(1) 14", (1) 16", (1) 22"		
Drive type	Direct Drive			
Motor HP range	1.3 / 2.3 / 4.0 / 8.0			
Hot gas reheat coil				
Coil Type	Microchannel			
Control Type	Modulating			
Temperature rise	20°			
Filters				
Type				
Area (sq ft)	7.1		16	
Qty. - size	4 – 16 x 16		6 – 18 x 24	

NOTE: 1. EER and IEER for Cooling Only VAV Unit
 2. Mixed Outside Air and Return Air units
 3. 100% Outside Air unit only

Physical Data

Physical Data—Unit Weights DPS 006 through 012

Model	Small Cabinet	Large Cabinet		
	006	007	010	012
	Weight (lbs.)			
Base Weight ¹	1058	1600	1600	1600
Heatpump	1058	1660	1660	1660
Electric Heat	45	100	100	100
Hot Water 2 Row	16.5	30	30	30
Hot Water 1 Row	20	31	31	31
Gas Heat	93	186	186	186
Hot Gas Re-heat	12	28	31	31
Economizer	163	308	308	308
Power Exhaust	201	346	346	346
High capacity coil	105	215	215	215

1. Includes standard cooling coil

Fan Weights (lbs.)	
12 Inch (310 mm)	87
14 Inch (360 mm)	91
16 Inch (400 mm)	115
22 Inch (560 mm)	115

Curb Weights (lbs.)		
	14"	24"
006	156	230
007—012	200	295

Fan Curves

Figure 16: Fan Curve – 12 inch Fan

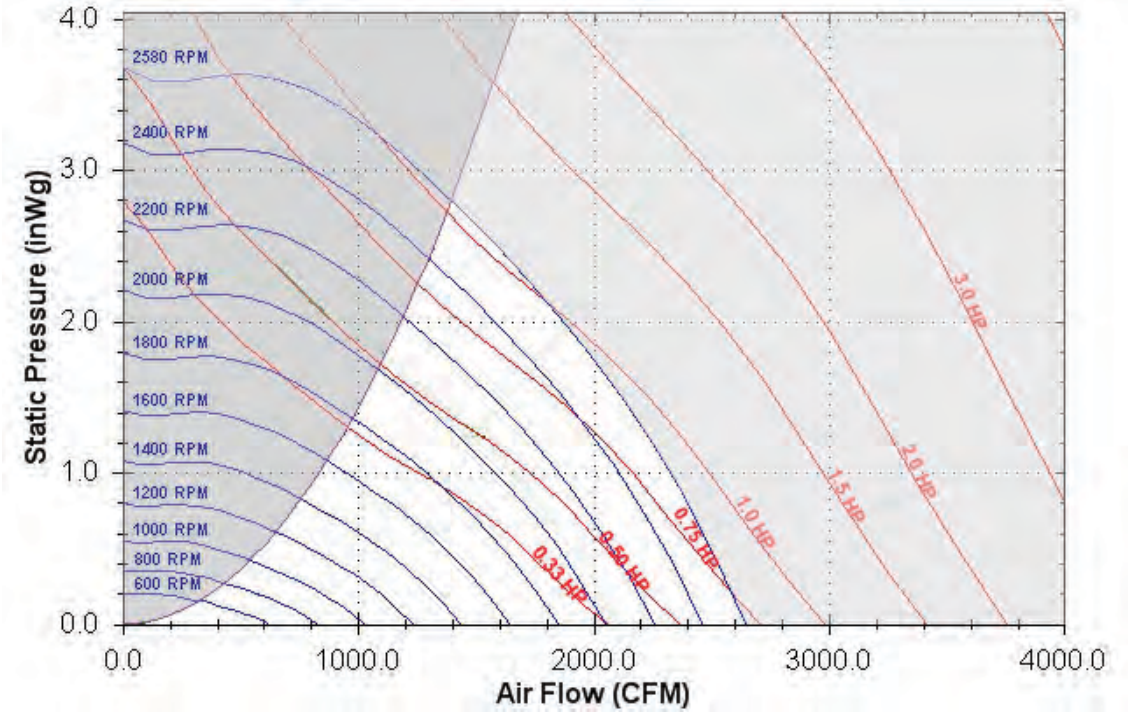
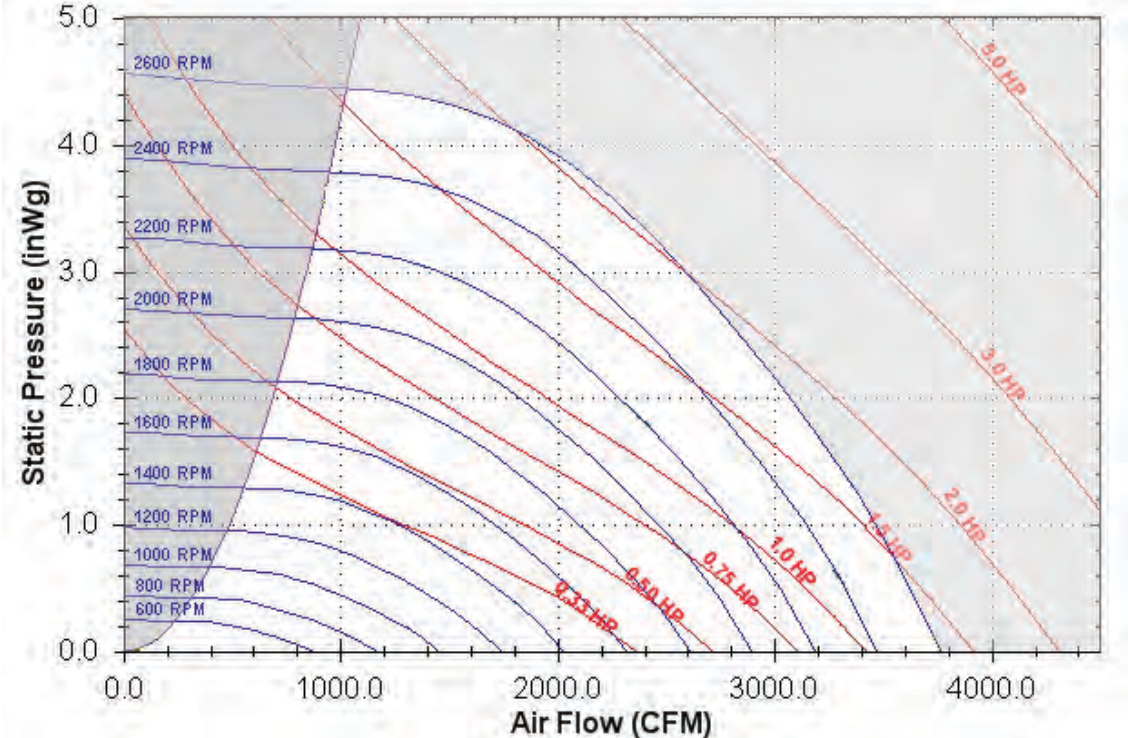

Figure 17: Fan Curve – 14 inch Fan



Performance Data

Figure 18: Fan Curve – 16 inch Fan

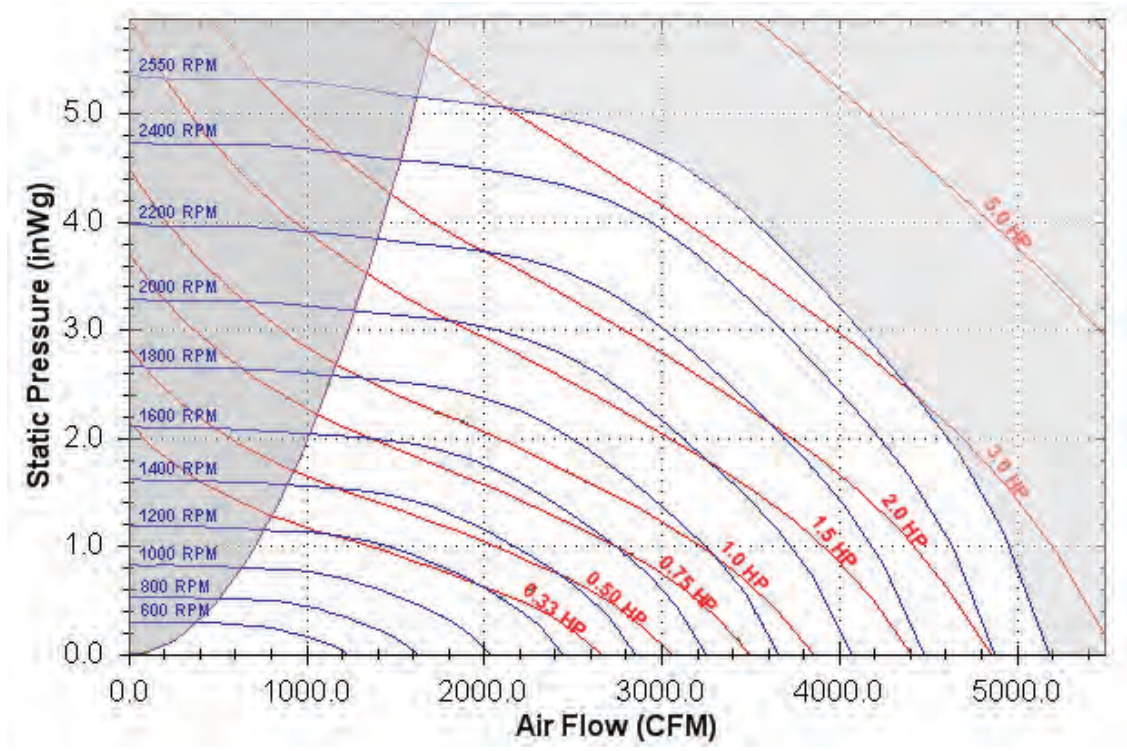
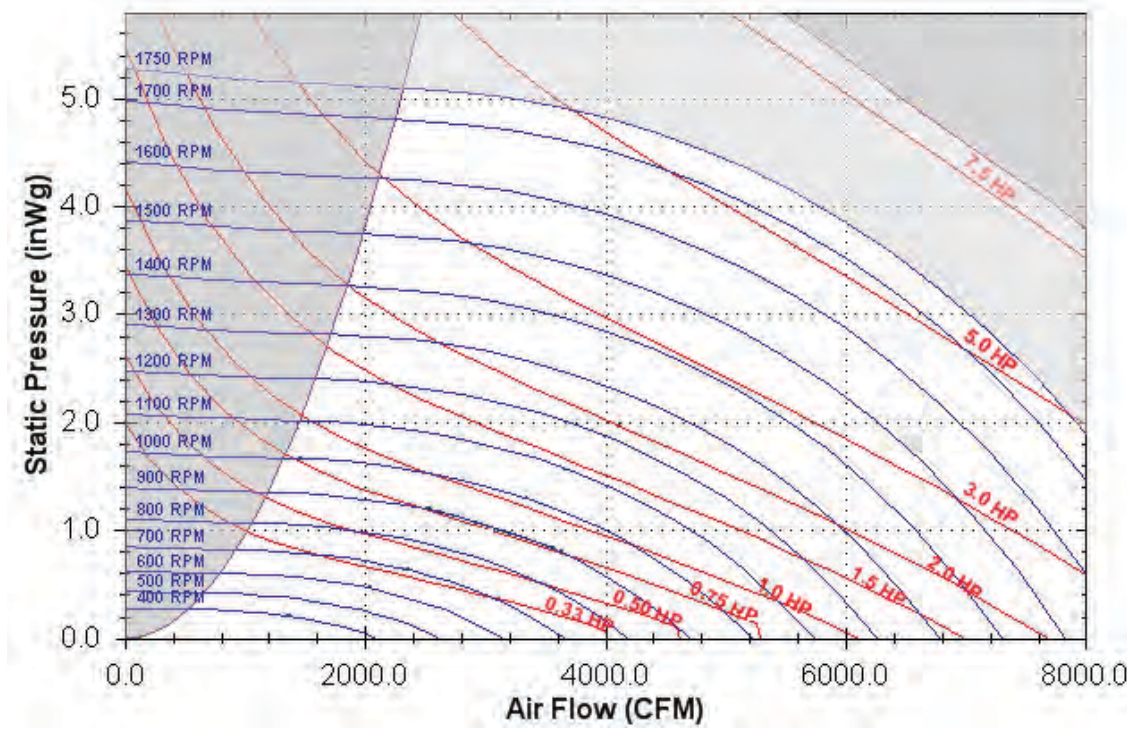

Figure 19: Fan Curve – 22 inch Fan



Heating Capacities

Table 2: Heating Capacity – Electric Heaters

Unit	Nominal (cfm)	Stages	Option # 1				Option # 2				Option # 3				Option # 4			
			KW	MBH	Delta T ¹	Min (cfm)	KW	MBH	Delta T ¹	Min (cfm)	KW	MBH	Delta T ¹	Min (cfm)	KW	MBH	Delta T ¹	Min (cfm)
006	2400	2, SCR	6	20.5	7.9	316	12	40.9	15.8	632	18	61.4	23.7	948	30	102.4	39.5	1580
007	3000	4, SCR	18	61.4	19.0	948	36	122.9	37.9	1896	54	184.3	56.9	2844	72.0 ²	245.8	60.0 ³	3793
010	4000	4, SCR	18	61.4	14.2	948	36	122.9	28.4	1896	54	184.3	42.7	2844	72.0 ²	245.8	56.9	3793
012	4800	4, SCR	18	61.4	11.9	948	36	122.9	23.7	1896	54	184.3	35.6	2844	72.0 ²	245.8	47.4	3793
015	6000	4, SCR	18	61.4	9.5	948	36	122.9	19.0	1896	54	184.3	28.4	2844	72.0 ²	245.8	37.9	3793

1. Temperature is calculated at nominal air flow

2. Not available in 208 & 230 Volt

3. 60 degree max rise

Table 3: Heating Capacity – Hot Water Coils

Unit	Nominal cfm	Low Heat				High Heat				
		MBH	Delta T ¹	GPM	Connection Size	Nominal cfm	MBH	Delta T ¹	GPM	Connection Size
006	2400	49	19.0	9	1.0"	2100	101	44.0	12	1.0"
007	2625	82	25.0	8	1.375"	2625	154	54.0	15	1.375"
010	4000	85	21.8	10		3500	188	49.0	20	
012	4800	105	19.9	11		4200	213	47.0	24	

1. Temperature is calculated at nominal air flow. Water temperature drop = 40°

Table 4: Heating Capacity – Gas Furnaces

Data	Unit Size					
	006			007 - 012		
	Low Heat	Med Heat	High Heat	Low Heat	Med Heat	High Heat
Heating Input	50	100	150	200	300	400
Heating Output	40	80	120	160	240	320
Steady State Efficiency	80%					
Number of Stages	2					
Turndown ¹	5:1			5:1	10:1	10:1

1. Modulating Heat Only

Performance Data

Air Pressure Drops

Table 5: Pressure Drop – Electric Heaters

Unit	Unit Airflow					
	1000	2000	3000	4000	5000	6000
006	0.11	0.36	0.77	—	—	—
007 – 012	0.02	0.07	0.14	0.23	0.34	0.48

Table 6: Pressure Drop – Hot Water Coils

Unit	Heat Type	Unit Airflow					
		1000	2000	3000	4000	5000	6000
006	Low (1 Row)	0.04	0.15	0.32	—	—	—
	High (2 Row)	0.11	0.37	0.83	—	—	—
007 - 012	Low (1 Row)	—	0.05	0.10	0.17	0.26	0.37
	High (2 Row)	—	0.11	0.23	0.39	0.59	0.83

Table 7: Pressure Drop – Gas Furnaces

Unit	Heat Type	Unit Airflow					
		1000	2000	3000	4000	5000	6000
006	Low (50 MBH)	0.08	0.33	0.74	—	—	—
	Medium (100 MBH)						
	High (150 MBH)						
007 – 012	Low (200 MBH)	0.02	0.07	0.14	0.23	0.35	0.49
	Medium (300 MBH)						
	High (400 MBH)						

Table 8: Pressure Drop – Components

Component	Unit	Unit Airflow					
		1000	2000	3000	4000	5000	6000
Economizer	006	0.01	0.05	0.11	—	—	—
	007 – 012	0.01	0.03	0.08	0.13	0.20	0.29
Filter	006	0.03	0.12	0.28	—	—	—
	007 – 012	0.01	0.02	0.06	0.09	0.15	0.22
Standard Cooling Coil	006	0.18	0.46	0.79	—	—	—
	007	0.03	0.09	0.14	0.20	0.25	0.33
	010 – 012	0.04	0.10	0.18	0.26	0.34	0.43
Hot Gas Reheat	006	0.03	0.07	0.13	—	—	—
	007 – 010	—	0.02	0.04	0.06	0.08	0.11
	012	—	0.02	0.03	0.05	0.07	0.09

Figure 20: DPS 006, Gas Heat, No Economizer

Gas Heat	Electric Heat, Hot Water Coils or Cooling Only	Economizer
		Economizer
X		No Economizer

Detail: A-B for Horizontal Supply and Return Air Openings

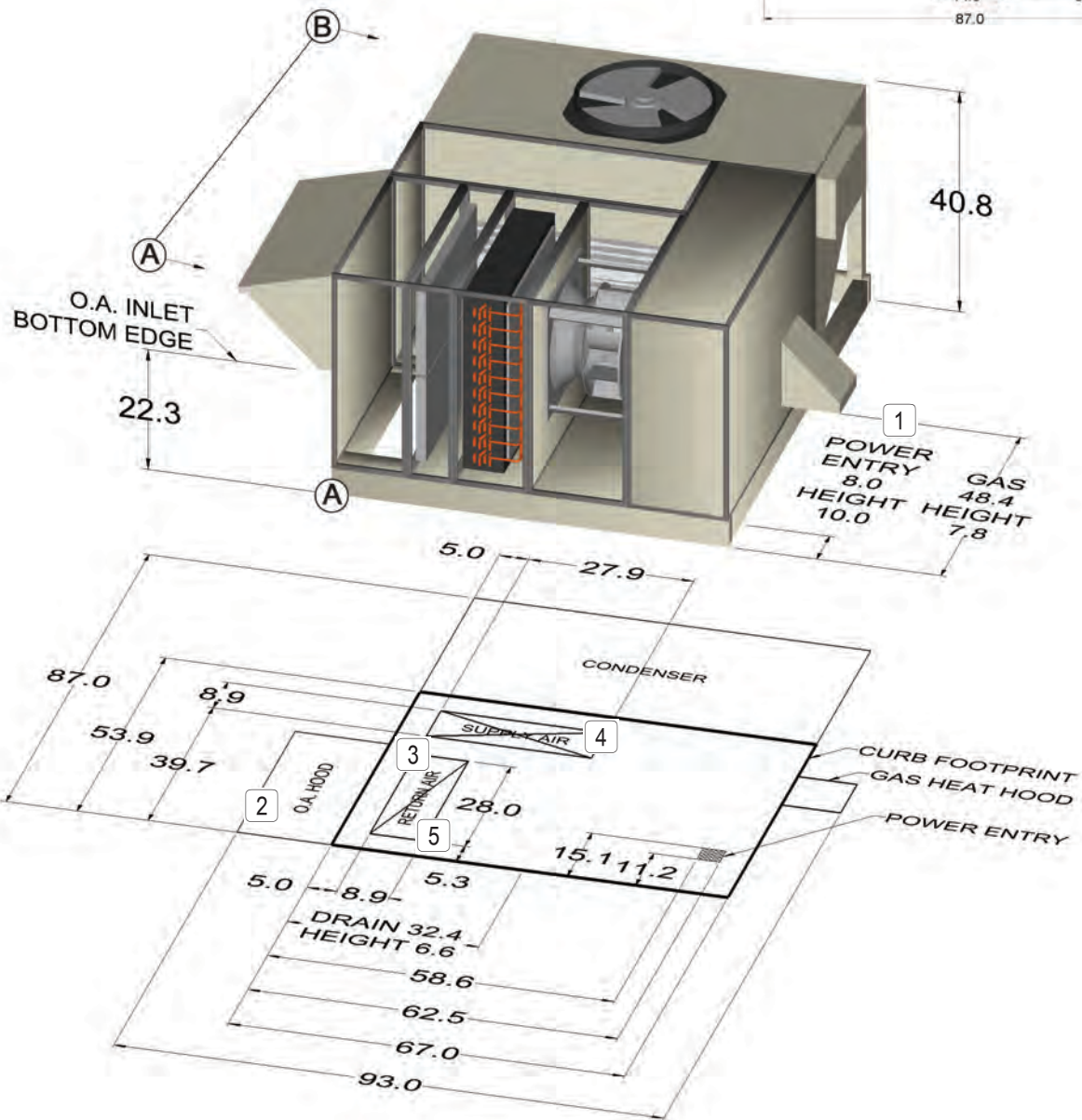
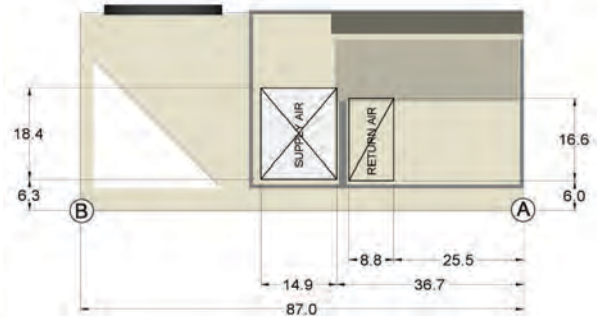

- NOTE:** Horizontal above the roof gas connection only
1. Recommended location for field cut side power connection
 2. Not provided on 100% Return Air units
 3. Not provided on 100% Outdoor Air units
 4. Not provided on units with Horizontal Supply Air opening
 5. Not provided on units with Horizontal Return Air opening

Dimensional Data

Figure 21: DPS 006, Hot Water Heat, Electric Heat, No Heat, No Economizer

Gas Heat	Electric Heat, Hot Water Coils or Cooling Only	
		Economizer
	X	No Economizer

Detail: A-B for Horizontal Supply and Return Air Openings

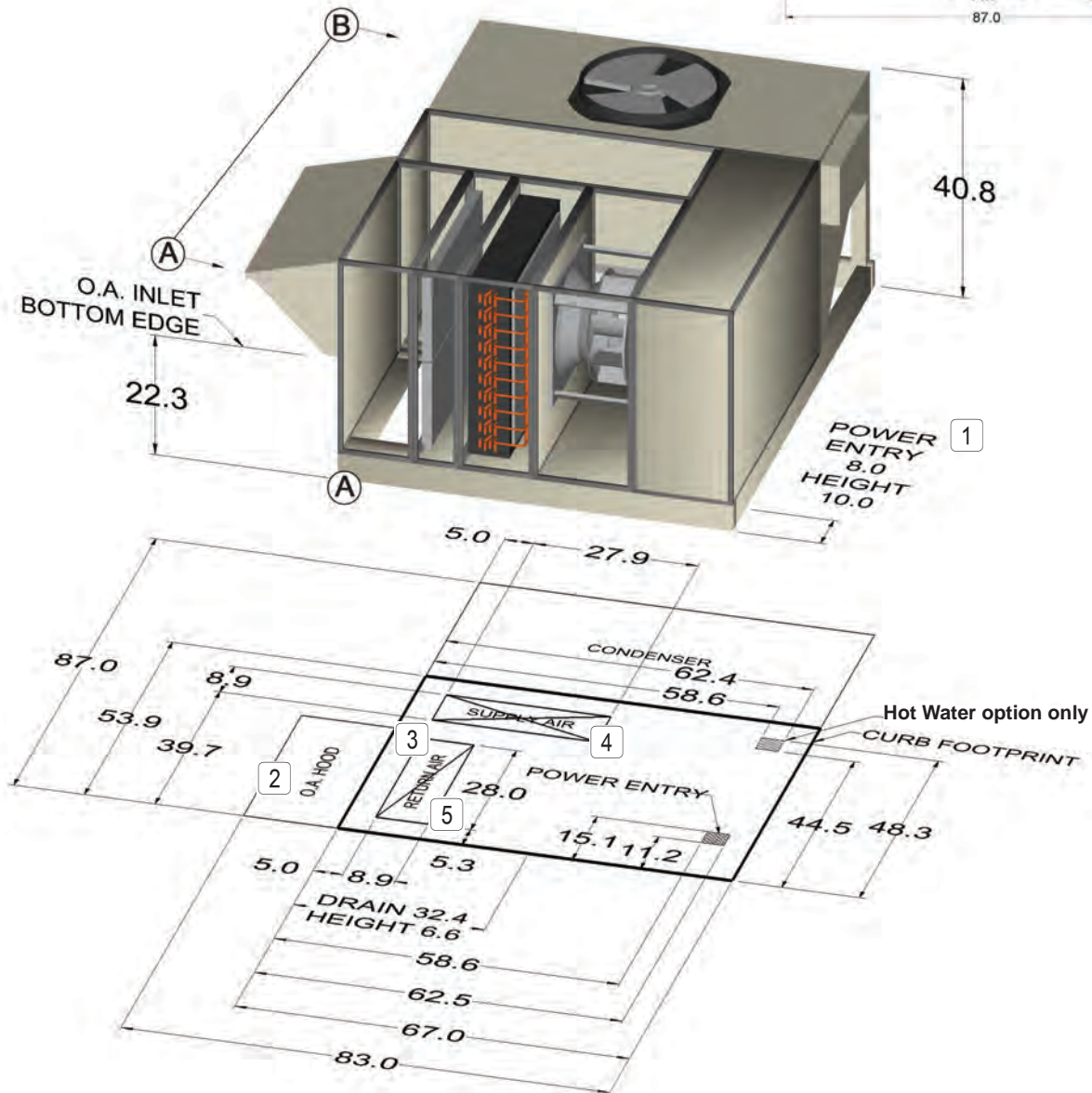
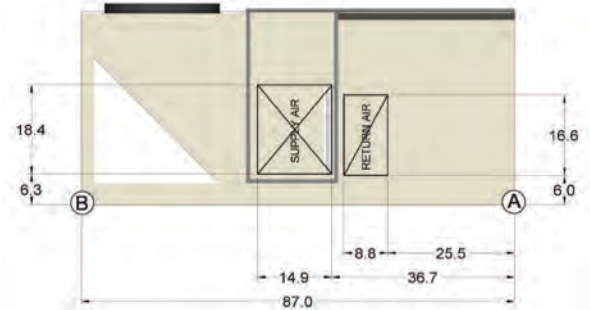

NOTE:

- 1. Recommended location for field cut side power connection
- 2. Not provided on 100% Return Air units
- 3. Not provided on 100% Outdoor Air units
- 4. Not provided on units with Horizontal Supply Air opening
- 5. Not provided on units with Horizontal Return Air opening

Figure 22: DPS 006, 100% Economizer, Gas Heat

Gas Heat	Electric Heat, Hot Water Coils or Cooling Only	
X		Economizer
		No Economizer

Detail: A-B for Horizontal Supply and Return Air Openings

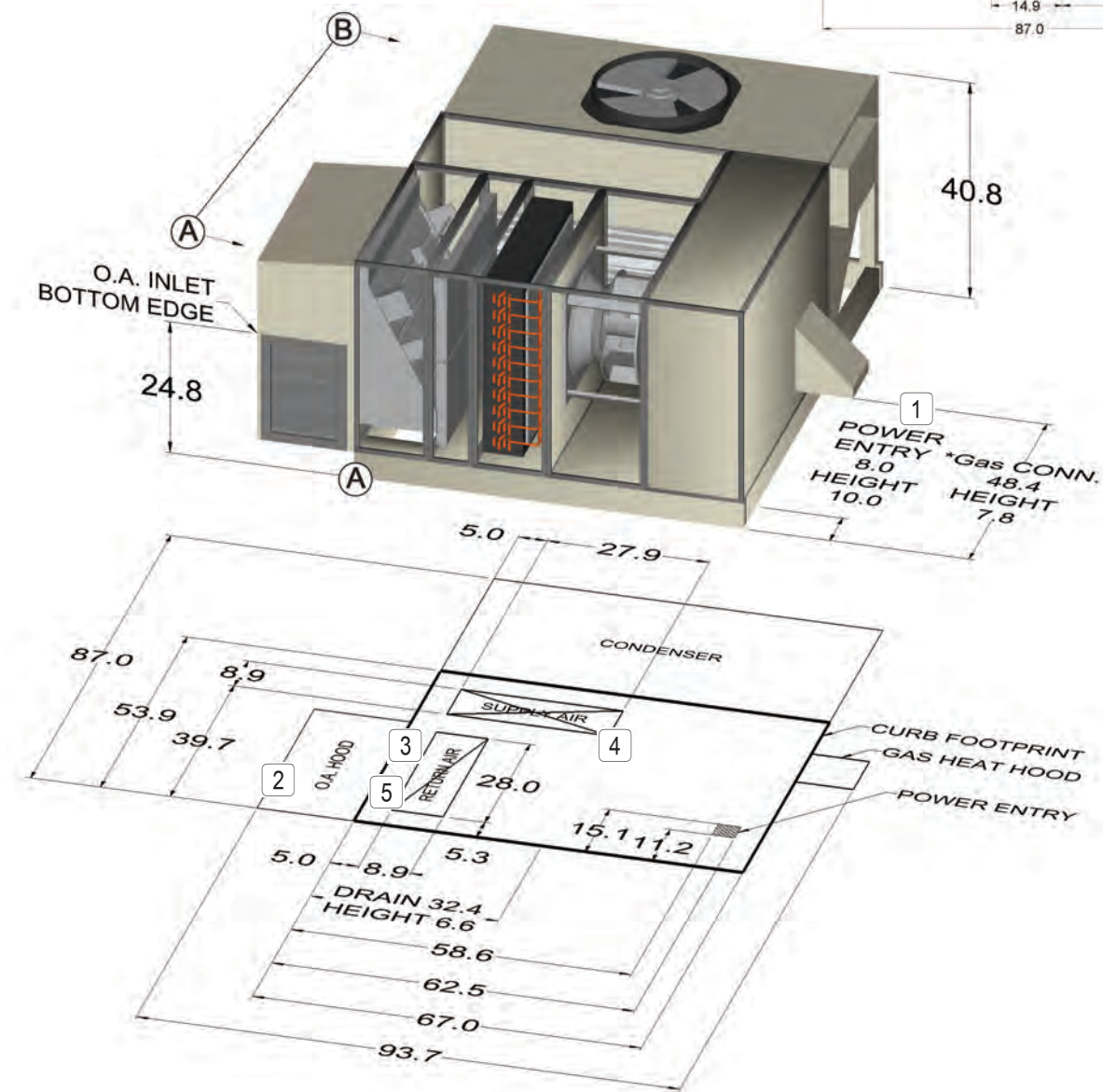
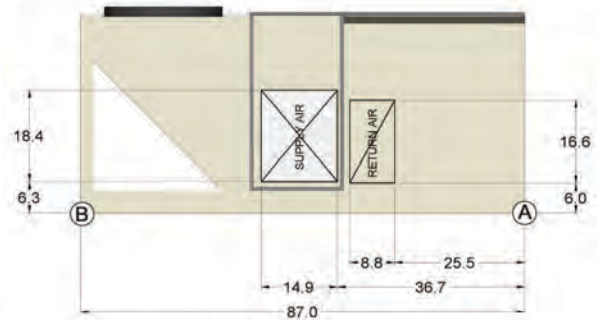

- NOTE:** Horizontal above the roof gas connection only
1. Recommended location for field cut side power connection
 2. Not provided on 100% Return Air units
 3. Not provided on 100% Outdoor Air units
 4. Not provided on units with Horizontal Supply Air opening
 5. Not provided on units with Horizontal Return Air opening

Dimensional Data

Figure 23: DPS 006, 100% Economizer, Hot Water Heat, Electric Heat, No Heat

Gas Heat	Electric Heat, Hot Water Coils or Cooling Only	
	X	Economizer
		No Economizer

Detail: A-B for Horizontal Supply and Return Air Openings

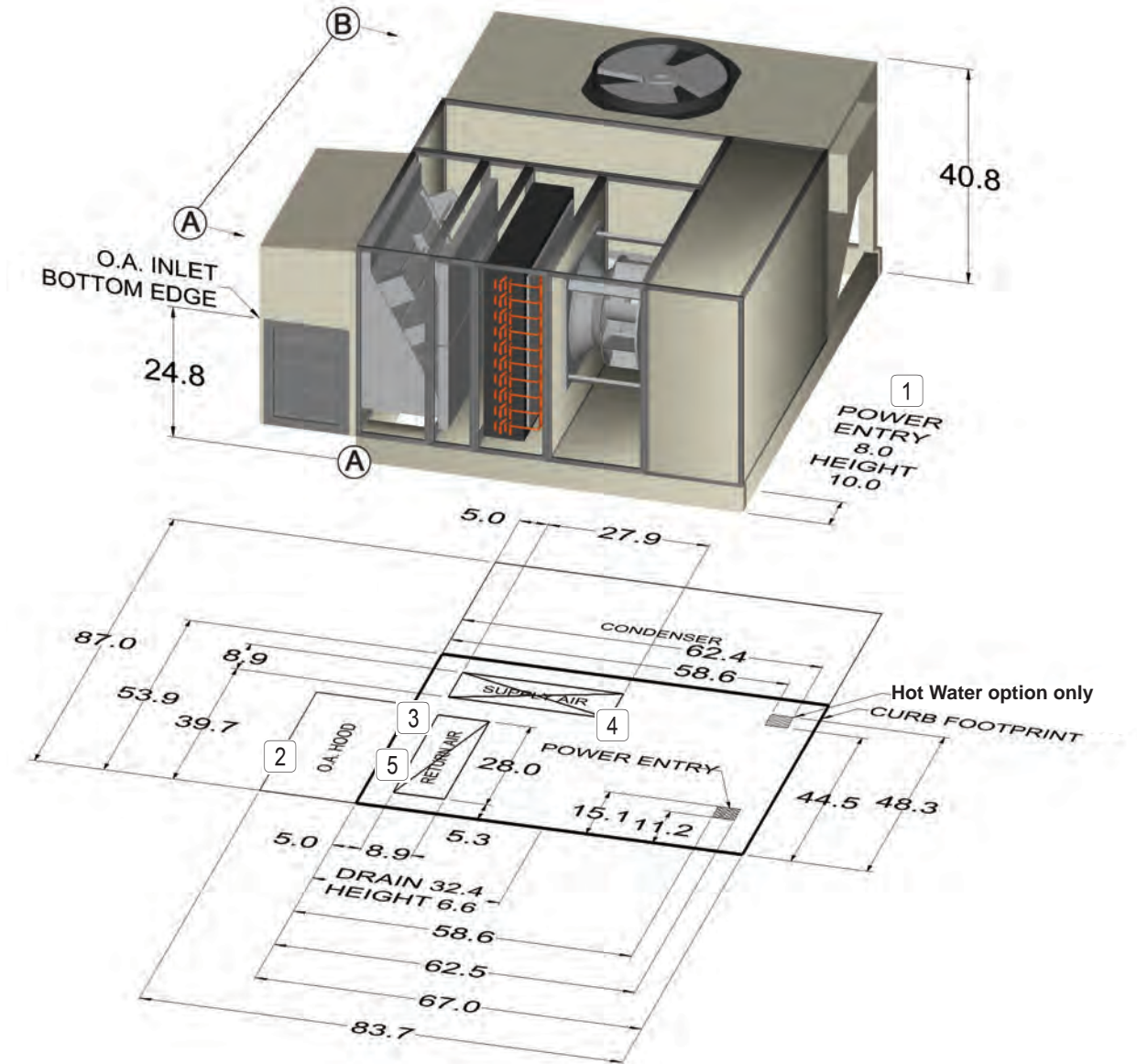
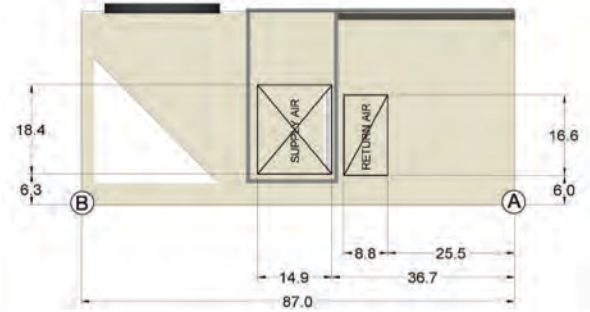

NOTE:

1. Recommended location for field cut side power connection
2. Not provided on 100% Return Air units
3. Not provided on 100% Outdoor Air units
4. Not provided on units with Horizontal Supply Air opening
5. Not provided on units with Horizontal Return Air opening

Figure 24: DPS 007-012, Hot Water Heat, Electric Heat, No Heat, No Economizer

Gas Heat	Electric Heat, Hot Water Coils or Cooling Only	
	X	Economizer
		No Economizer

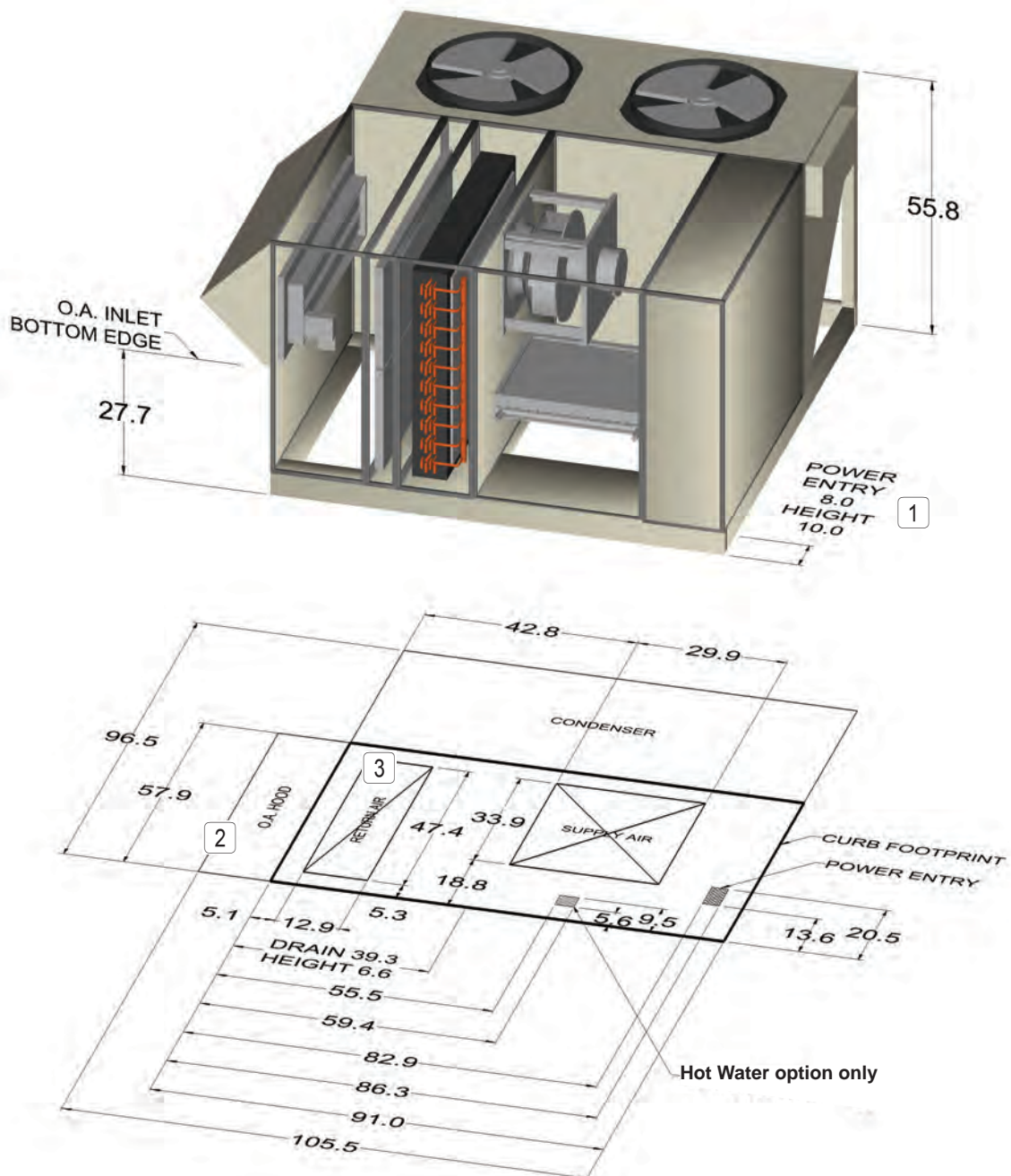

- NOTE:** Horizontal above the roof gas connection only
1. Recommended location for field cut side power connection
 2. Not provided on 100% Return Air units
 3. Not provided on 100% Outdoor Air units

Dimensional Data

Figure 25: DPS 007-012, Gas Heat, No Economizer

Gas Heat	Electric Heat, Hot Water Coils or Cooling Only	Economizer
		Economizer
X		No Economizer

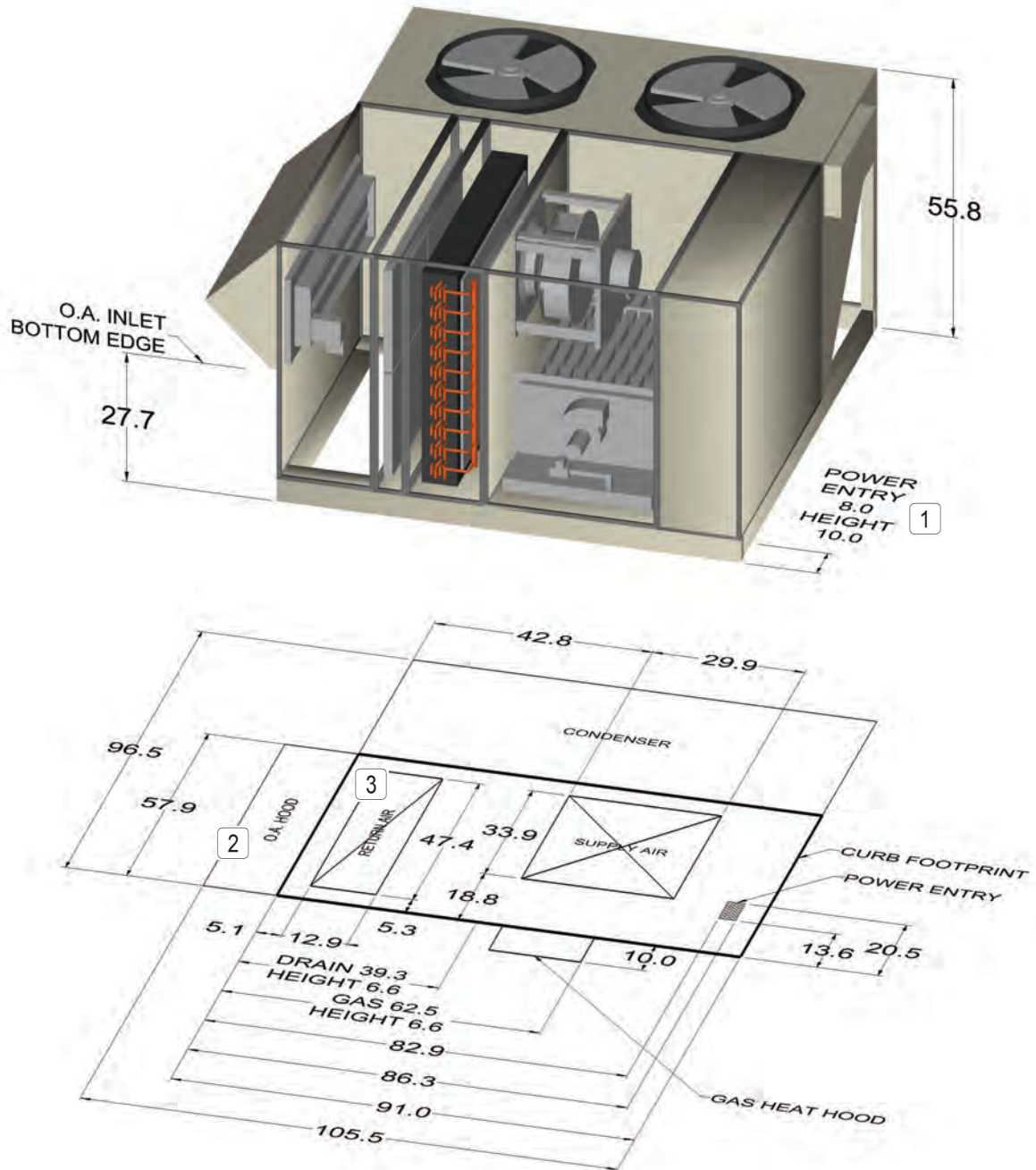

- NOTE:** Horizontal above the roof gas connection only
1. Recommended location for field cut side power connection
 2. Not provided on 100% Return Air units
 3. Not provided on 100% Outdoor Air units

Figure 26: DPS 007-012, 100% Economizer, Gas heat

Gas Heat	Electric Heat, Hot Water Coils or Cooling Only	
X		Economizer
		No Economizer

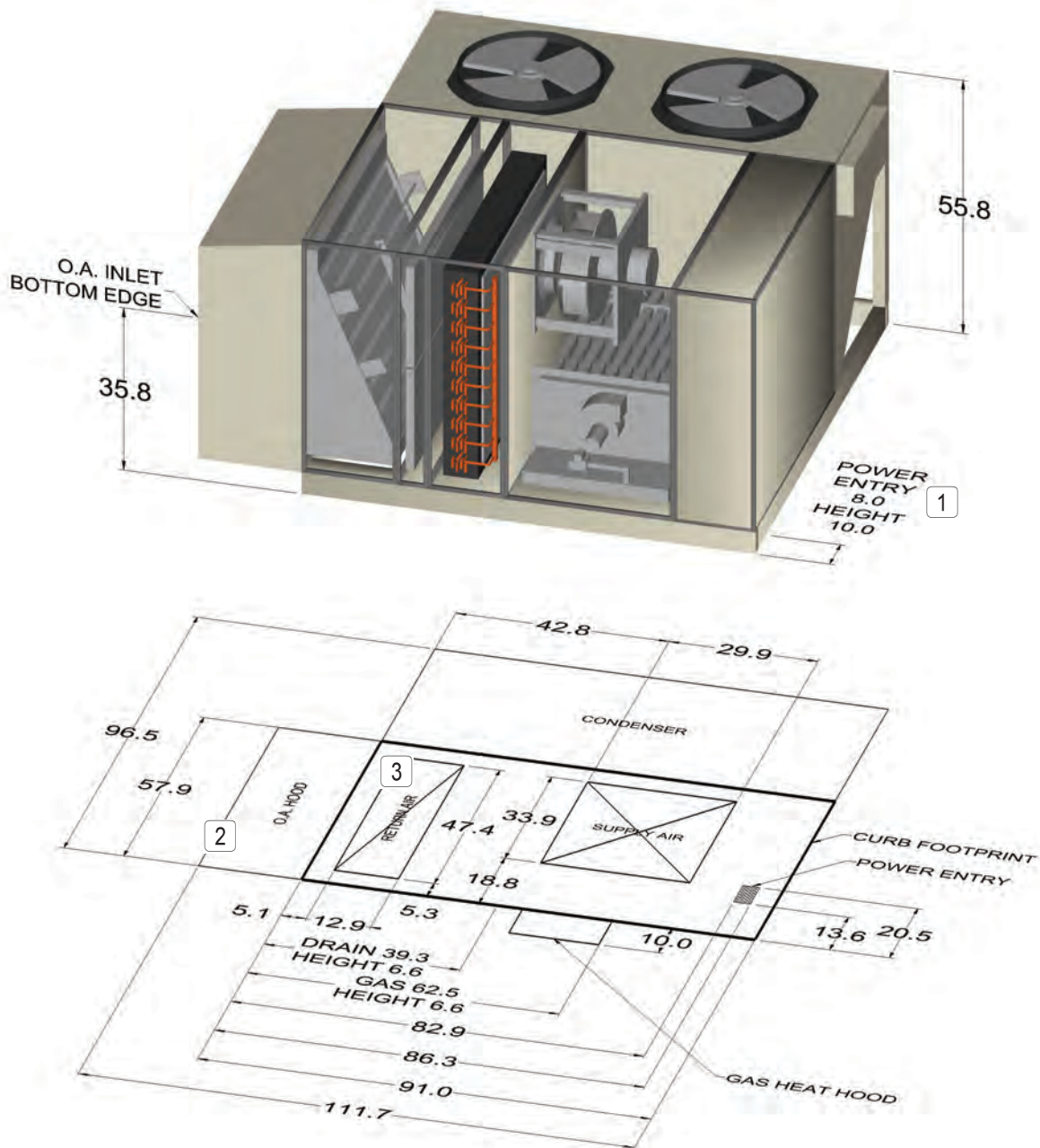

NOTE: Horizontal above the roof gas connection only

1. Recommended location for field cut side power connection
2. Not provided on 100% Return Air units
3. Not provided on 100% Outdoor Air units

Dimensional Data

Figure 27: DPS 007-012, 100% Economizer, Hot Water Heat, Electric Heat, No Heat

Gas Heat	Electric Heat, Hot Water Coils or Cooling Only	
	X	Economizer
		No Economizer

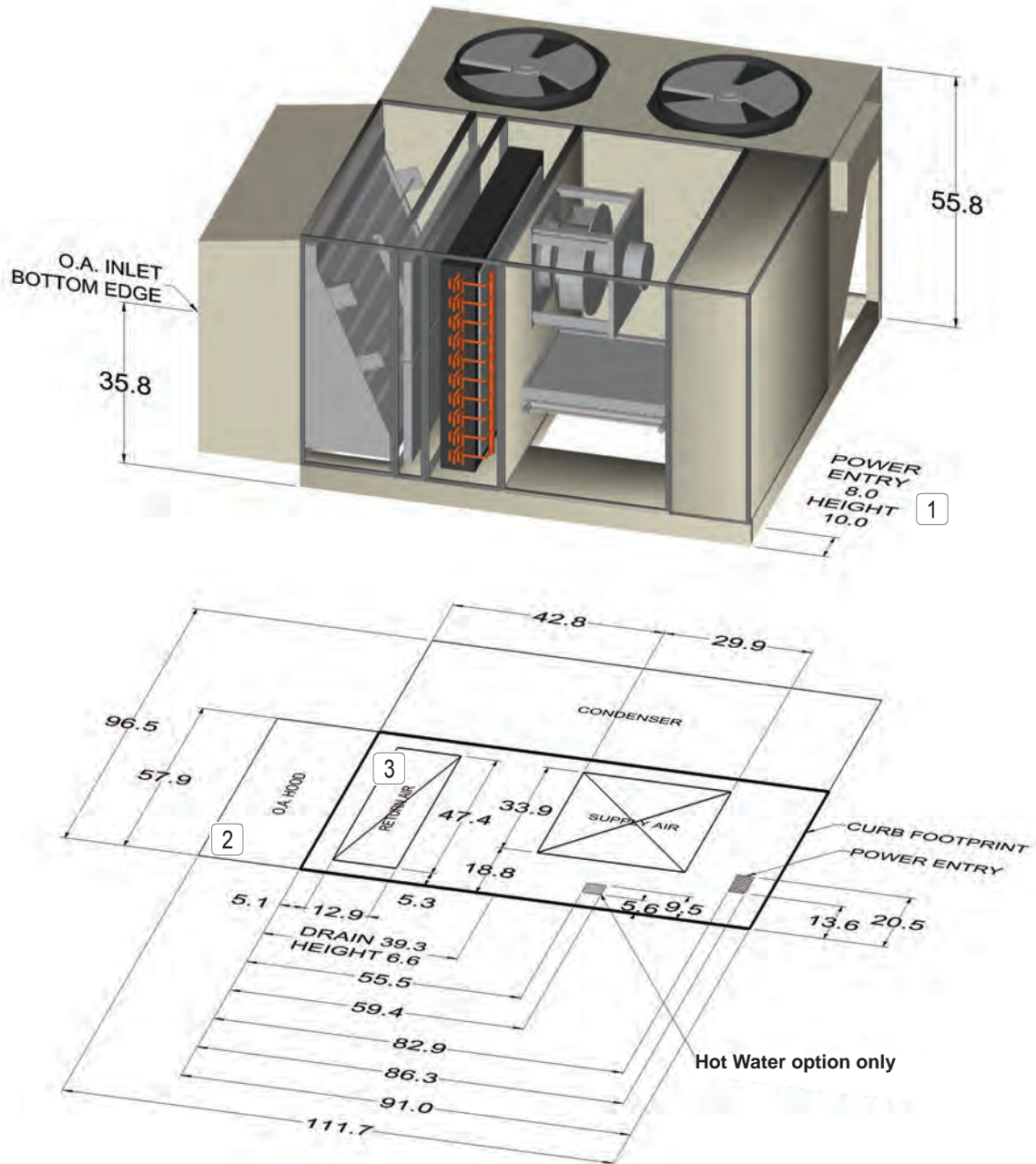

- NOTE:** Horizontal above the roof gas connection only
1. Recommended location for field cut side power connection
 2. Not provided on 100% Return Air units
 3. Not provided on 100% Outdoor Air units

Table 9: Electric Heat Data¹

kW	Voltage	Amps	kW	Voltage	Amps
6	208	16.7	36	208	99.9
	230	15.1		230	90.4
	475	7.3		475	43.8
	575	6.0		575	36.1
12	208	33.3	54	208	149.9
	230	30.1		230	135.6
	475	14.6		475	65.6
	575	12.0		575	54.2
18	208	50.0	72	—	—
	230	45.2		—	—
	475	21.9		475	87.5
	575	18.1		575	72.3
30	208	83.3			
	230	75.3			
	475	36.5			
	575	30.1			

1. Maximum temperature rise equals 60°F

Table 10: Amp Draw Data

Unit Size	Compressor RLA						Compressor LRA						Compressor Size		Condenser Fan FLA*				
	Compressor 1 - Variable				Compressor 3 - Fixed		Compressor 1			Compressor 3			Comp 1	Comp 3	Qty	208	230	460	
	208	230	460	[%]	208	230	460	208	230	460	208	230	460	[P/N]					[P/N]
6	15.0	13.6	6.8	89.0%	0.0	0.0	0.0	143.8	130.0	65.0	0.0	0.0	0.0	JT1G	NA	1	2.0	1.8	0.9
7.5	11.9	10.8	5.4	68.0%	8.6	7.8	3.9	143.8	130.0	65.0	67.5	73.7	37.1	JT1G	JT71G	2	2.0	1.8	0.9
10	10.0	9.0	4.5	59.0%	17.5	15.8	7.9	143.8	130.0	65.0	93.1	84.2	42.1	JT1G	JT170G	2	2.0	1.8	0.9
12	15.0	13.6	6.8	89.0%	17.5	15.8	7.9	143.8	130.0	65.0	93.1	84.2	42.1	JT1G	JT170G	2	2.0	1.8	0.9

Horse Power	Supply Fan FLA				Exhaust Fan FLA			
	Voltage				Voltage			
	208	230	460	kW	208	230	460	kW
1.3	3.1	2.8	1.4	1.0	3.1	2.8	1.4	1.0
2.3	5	4.6	2.3	1.7	5	4.6	2.3	1.7
4	8.8	7.4	4.0	3.0	8.8	7.4	4.0	3.0
8	13.5	12.2	6.1	6.0	—	—	—	—

* Values are for total condenser fan FLA, on 7.5-12 and 15T units the value include both fans
 575V Amp Draws: Compressors and motors will be run off a 575 to 460V transformer. Motors will be nameplated at 460V. 575 voltage is for large cabinet only.
 For MCA & MOP calculations the motor's FLA will be multiplier by 80% (575/460) and calculation is run as normal.

Table 11: Recommended Field Power Wiring

Ampacity (MCA)	Number of Power Wires Per Phase	Wire Gauge	Insulation Temperature Rating (°C)
30	1	10	75
40	1	8	75
55	1	6	75
70	1	4	75
85	1	3	75
95	1	2	75
130	1	1	75
150	1	1/0	75
175	1	2/0	75
200	1	3/0	75
230	1	4/0	75
255	1	250	75

1. All wire sizes assume separate conduit for each set of parallel conductors.
2. All wire sizes based on NEC Table 310-16 for 75°C THW wire (copper). Canadian electrical code wire ampacities may vary.
3. All wire sizes assume no voltage drop for short power leads.

Engineering Specifications

Part 1: General

1.01 Section Includes:

- A. Packaged rooftop air conditioners

1.02 References

- A. AFBMA 9—Load Ratings and Fatigue Life for Ball Bearings.
- B. AMCA 99—Standards Handbook
- C. AMCA 210—Laboratory Methods of Testing Fans for Rating Purposes
- D. AMCA 500—Test Methods for Louver, Dampers, and Shutters.
- E. ARI 340/360 - Unitary Large Equipment
- F. NEMA MG1—Motors and Generators
- G. National Electrical Code.
- H. NFPA 70—National Fire Protection Agency.
- I. SMACNA—HVAC Duct Construction Standards—Metal and Flexible.
- J. UL 900—Test Performance of Air Filter Units.

1.03 Submittals

- A. Shop Drawings: Indicate assembly, unit dimensions, weight loading, required clearances, construction details, field connection details, electrical characteristics and connection requirements.
- B. Product Data:
 - 1. Provide literature that indicates dimensions, weights, capacities, ratings, fan performance, and electrical characteristics and connection requirements.
 - 2. Provide computer generated fan curves with specified operating point clearly plotted.
 - 3. Manufacturer's Installation Instructions.

1.04 Operation and Maintenance Data

- A. Maintenance Data: Provide instructions for installation, maintenance and service

1.05 Qualifications

- A. Manufacturer: Company specializing in manufacturing the Products specified in this section with minimum five years documented experience, who issues complete catalog data on total product.
- B. Startup must be done by trained personnel experienced with rooftop equipment.

- C. Do not operate units for any purpose, temporary or permanent, until ductwork is clean, filters and remote controls are in place, bearings lubricated, and manufacturers' installation instructions have been followed.

1.06 Delivery, Storage, and Handling

- A. Deliver, store, protect and handle products to site.
- B. Accept products on site and inspect for damage.
- C. Store in clean dry place and protect from weather and construction traffic. Handle carefully to avoid damage to components, enclosures, and finish.

Part 2: Products

2.01 Manufacturers

- A. Basis of Design: McQuay International
 - 1. No equals exist. [Deducts for alternative equipment will be considered.]

2.02 General Description

- A. Furnish as shown on plans, McQuay Rebel Rooftop Heating and Cooling Unit(s) model DPS. Unit performance and electrical characteristics shall be per the job schedule.
- B. Configuration: Fabricate as detailed on prints and drawings:
 - 1. Return plenum / economizer section
 - 2. Filter section
 - 3. Cooling coil section
 - 4. Supply fan section
 - 5. Gas heating section
 - 6. Condensing unit section
- C. The complete unit shall be citrus listed.
- D. Each unit shall be specifically designed for outdoor rooftop application and include a weatherproof cabinet. Each unit shall be completely factory assembled and shipped in one piece. Packaged units shall be shipped fully charged with R-410A Refrigerant and oil.
- E. The unit shall undergo a complete factory run test prior to shipment. The factory test shall include a refrigeration circuit run test, a unit control system operations checkout, a unit refrigerant leak test and a final unit inspection.

- F. All units shall have decals and tags to indicate caution areas and aid unit service. Unit nameplates shall be fixed to the main control panel door. Electrical wiring diagrams shall be attached to the control panels. Installation, operating and maintenance bulletins and start-up forms shall be supplied with each unit.
- G. Performance: All scheduled EER, IEER, capacities and face areas are minimum accepted values and must be met. All scheduled amps, kW, and HP are maximum accepted values.
- H. Warranty: The manufacturer shall provide 12-month parts only warranty. Defective parts shall be repaired or replaced during the warranty period at no charge. The warranty period shall commence at startup or six months after shipment, whichever occurs first.

2.03 Cabinet, Casing, and Frame

- A. Panel construction shall be double-wall construction for all panels including the floor panels. Equipment shall have an under floor liner. Insulation shall be a minimum of 1" thick with an R-value of 7.0 and shall be 2 part injected foam. Panel design shall include no exposed insulation edges. Unit cabinet shall be designed to operate at total static pressures up to 5.0 inches w.g.
- B. Exterior surfaces shall be constructed of pre-painted galvanized steel for aesthetics and long term durability. Paint finish to include a base primer with a high quality, polyester resin topcoat of a neutral beige color. Finished panel surfaces to withstand a minimum 750-hour salt spray test in accordance with ASTM B117 standard for salt spray resistance.
- C. Service doors shall be provided on the fan section, filter section, control panel section, and heating vestibule in order to provide user access to unit components. All service access doors shall be mounted on multiple, stainless steel hinges and shall be secured by a latch system. Removable service panels secured by multiple mechanical fasteners are not acceptable.
- D. The unit base shall overhang the roof curb for positive water runoff and shall seat on the roof curb gasket to provide a positive, weather tight seal. Lifting brackets shall be provided on the unit base to accept cable or chain hooks for rigging the equipment. Fork lift slots shall be provided in the unit base.

2.04 Outdoor Air Damper Section

- A. Unit shall be provided with a 0~30% outdoor air damper and mixing section. The outdoor air hood shall be factory installed and constructed from the same durable paint finish as the main unit. The hood shall include moisture eliminator filters to drain water away from the entering air stream. The damper blades shall be gasketed with side seals to provide an air leakage rate of 4 cfm/square foot of damper area at 1" differential pressure per ASHRAE 90.1 Energy Standard. Control of the dampers shall be by a factory installed direct coupled actuator. Damper actuator shall be of the modulating, spring return type. The unit controller shall be capable of resetting the minimum damper position.

2.05 Economizer Section

- A. Unit shall be provided with an outdoor air economizer. The economizer section shall include outdoor, return, and exhaust air dampers. The economizer operation shall be fully integral to the mechanical cooling and allow up to 100% of mechanical cooling if needed to maintain the cooling discharge air temperature. The outdoor air hood shall be factory installed and constructed from galvanized steel finished with the same durable paint finish as the main unit. The hood shall include moisture eliminator filters to drain water away from the entering air stream. The outside and return air dampers shall be sized to handle 100% of the supply air volume. The dampers shall be parallel blade design. Damper blades shall be gasketed with side seals to provide an air leakage rate of 4 cfm / square foot of damper area at 1" differential pressure per ASHRAE 90.1 Energy Standard. A barometric exhaust damper shall be provided to exhaust air out of the back of the unit. A bird screen shall be provided to prevent infiltration of rain and foreign materials. Exhaust damper blades shall be lined with vinyl gasketing on contact edges. Control of the dampers shall be by a factory installed direct coupled actuator. Damper actuator shall be of the modulating, spring return type. A comparative enthalpy control shall be provided to sense and compare enthalpy in both the outdoor and return air streams to determine if outdoor air is suitable for "free" cooling. If outdoor air is suitable for "free" cooling, the outdoor air dampers shall modulate in response to the unit's temperature control system.

Engineering Specifications

2.06 Exhaust Fan

- A. Exhaust fan shall be a single width, single inlet (SWSI) airfoil centrifugal fan. The fan wheel shall be Class II construction with aluminum fan blades that are continuously welded to the hub plate and end rim. The exhaust fan shall be a direct drive fan mounted to the motor shaft
- B. The fan motor shall be a totally enclosed EC motor that is speed controlled by the rooftop unit controller. The motor shall include thermal overload protection and protect the motor in the case of excessive motor temperatures. The motor shall have phase failure protection and prevent the motor from operation in the event of a loss of phase. Motors shall be premium efficiency.
- C. Fan assembly shall be a slide out assembly for servicing and maintenance.
- D. The unit DDC controller shall provide building static pressure control. The unit controller shall provide proportional control of the exhaust fans from 25% to 100% of the supply air fan designed airflow to maintain the adjustable building pressure set point. The field shall mount the required sensing tubing from the building to the factory mounted building static pressure sensor.

2.07 Filters

A. Unit shall be provided with a draw-through filter section. The filter rack shall be designed to accept a 2" prefilter and a 4" final filter. The unit design shall have a hinged access door for the filter section. The manufacturer shall ship the rooftop unit with 2" construction filters. The contractor shall furnish and install, at building occupancy, the final set of filters per the contract documents.

2.08 Cooling Section

- A. The indoor coil section shall be installed in a draw through configuration, upstream of the supply air fan. The coil section shall be complete with a factory piped cooling coil and an ASHRAE 62.1 compliant double sloped drain pan.
- B. The direct expansion (DX) cooling coils shall be fabricated of seamless high efficiency copper tubing that is mechanically expanded into high efficiency aluminum plate fins. Coils shall be a multi-row, staggered tube design with a minimum of 3 rows. All cooling coils shall have an interlaced coil circuiting that keeps the full coil face active at all load conditions. All coils shall be factory leak tested with high pressure air under water.

- C. The cooling coil shall have an electronic controlled expansion valve. The unit controller shall control the expansion valve to maintain liquid subcooling and the superheat of the refrigerant system.
- D. The refrigerant suction lines shall be fully insulated from the expansion valve to the compressors.
- E. The drain pan shall be stainless steel and positively sloped. The slope of the drain pan shall be in two directions and comply with ASHRAE Standard 62.1. The drain pan shall have a minimum slope of 1/8" per foot to provide positive draining. The drain pan shall extend beyond the leaving side of the coil. The drain pan shall have a threaded drain connection extending through the unit base.

2.09 Hot Gas Reheat

- A. Unit shall be equipped with a fully modulating hot gas reheat coil with hot gas coming from the unit condenser.
- B. Hot gas reheat coil shall be a Micro Channel design. The aluminum tube shall be a micro channel design with high efficiency aluminum fins. Fins shall be brazed to the tubing for a direct bond. The capacity of the reheat coil shall allow for a 20°F temperature rise at all operating conditions.
- C. The modulating hot gas reheat systems shall allow for independent control of the cooling coil leaving air temperature and the reheat coil leaving air temperature. The cooling coil and reheat coil leaving air temperature setpoints shall be adjustable through the unit controller. During the dehumidification cycle the unit shall be capable of 100% of the cooling capacity. The hot gas reheat coil shall provide discharge temperature control within +/- 2°F.
- D. Each coil shall be factory leak tested with high-pressure air under water.

2.10 Supply Fan

- A. Supply fan shall be a single width, single inlet (SWSI) airfoil centrifugal fan.

The fan wheel shall be Class II construction with aluminum fan blades that are continuously welded to the hub plate and end rim. The supply fan shall be a direct drive fan mounted to the motor shaft.
- B. Fan assembly shall be a slide out assembly for servicing and maintenance.
- C. All fan assemblies shall be statically and dynamically balanced at the factory, including a final trim balance, prior to shipment.

- D. The fan motor shall be a totally enclosed EC motor that is speed controlled by the rooftop unit controller. The motor shall include thermal overload protection and protect the motor in the case of excessive motor temperatures. The motor shall have phase failure protection and prevent the motor from operation in the event of a loss of phase. Motors shall be premium efficiency.
- E. The supply fan shall be capable of airflow modulation from 30% to 100% of the scheduled designed airflow. The fan shall not operate in a state of surge at any point within the modulation range.

2.11 Variable Air Volume Control

- A. The unit controller shall proportionally control the ECM, Electronically Commutated Motor on the supply and exhaust fans. The supply fan shall be controlled to maintain an adjustable duct pressure set point. A duct static pressure sensor shall be factory mounted in the control panel. The field shall furnish and install the pneumatic tubing for the duct static pressure sensor and the building pressure sensor. The field shall furnish and install the outdoor air pressure sensor.
- B. The unit controller shall proportional control the ECM motors on the supply fan based on space temperature. The unit controller shall increase/decrease the speed of the supply fan in order to maintain the space temperature within its setpoint and deadband. The unit controller shall provide discharge air temperature control with the compressor modulation.

2.12 Natural Gas Heating Section

- A. The rooftop unit shall include a natural gas heating section. The gas furnace design shall be a natural gas fired heating module factory installed downstream of the supply air fan in the heat section. The heating module shall be a tubular design with in-shot gas burners.
- B. Each module shall have two stages of heating control. The heat exchanger tubes shall be aluminized steel.
- C. The heat exchanger tubes shall be stainless steel. The module shall be complete with a furnace controller and control valve capable of 5:1 modulation.
- D. The heat exchanger tubes shall be stainless steel. The module shall be complete with a furnace controller and control valve capable of 10:1 modulation.

- E. The module shall have an induced draft fan that will maintain a negative pressure in the heat exchanger tubes for the removal of the flue gases.
- F. Each burner module shall have two flame roll-out safety protection switches and a high temperature limit switch that will shut the gas valve off upon detection of improper burner manifold operation. The induced draft fan shall have an airflow safety switch that will prevent the heating module from turning on in the event of no airflow in the flue chamber.
- G. The factory-installed DDC unit control system shall control the gas heat module. Field installed heating modules shall require a field ETL certification. The manufacturer's rooftop unit ETL certification shall cover the complete unit including the gas heating modules.

2.13 Electric Heating Section

- A. The rooftop unit shall include an electrical resistance heating coil section. The electric heating coil module shall be factory installed downstream of the supply air fan in the heating section of the rooftop unit. Heating elements shall be constructed of a low watt density, nickel - chromium alloy resistance wire with intermediate supports that include ceramic bushings. The electrical relay contactors shall be of the full line-breaking type with all the electrical power legs being disconnected when the contactors are not energized. All electrical circuit wiring shall be designed with copper conductors, aluminum wires are not acceptable. Heating element branch circuits shall be individually fused to a maximum of 48 Amps per NEC requirements. The rooftop unit shall have a single point power connection. The power supply for the electric heater shall be factory wired into the units main power block or disconnect switch.
- B. The heating modules shall have an automatic reset, high temperature limit safety protection. A secondary high limit protection shall also be provided that requires a manual reset. An airflow switch shall be provided with the heating module to prevent the electric heater from operating in the event of no airflow.
- C. The electric heater elements shall be controlled by the factory installed DDC unit control system. The heater shall have 4 stages of control.

Engineering Specifications

- D. The electric heat elements shall be controlled by the factory installed DDC unit control system. The heater shall have proportional SCR control. The unit controller shall modulate the electric heater to maintain the discharge air temperature setpoint.
- E. Field installed heating modules shall require a field ETL certification. Duct heaters mounted within the rooftop unit in the field shall not be acceptable. The manufacturer's rooftop unit ETL certification shall cover the complete unit including the electric heating modules.

2.14 Hot Water Heating Section

- A. A hot water heating coil shall be factory installed in the heat section. The hot water heat section shall be installed downstream of the supply air fan. A factory-tested diffuser shall be used in order to provide air distribution across the coil. The rooftop unit shall include a piping vestibule. The coil connection shall terminate in the vestibule. All coil connections shall be copper, steel connections shall not be allowed in order to prevent dielectrics and corrosion.
- B. Coils shall be fabricated of seamless 3/8" diameter copper tubing that is mechanically expanded into high efficiency rippled and corrugated aluminum plate fins. All coil vents and drains shall be factory installed. Hot water coil shall be fully cased to allow for easy replacement.
- C. The control valve shall be field supplied and installed in the heating vestibule. The control valve shall be capable of receiving a 2 – 10vdc signal. The wire harness from the unit controller to the control valve shall be factory installed.
- D. The coil shall have freeze protection and shall be controlled by the unit DDC controller. With the detection of a freeze condition the heating coil valve shall be driven fully open. The unit controller shall indicate an alarm.
- E. Coil shall be factory leak tested with high pressure air under water.

2.15 Condensing Section

- A. Outdoor coils shall have seamless copper tubes, mechanically bonded into aluminum plate-type fins. The fins shall have fully drawn collars to completely cover the tubes. A sub-cooling coil shall be an integral part of the main outdoor air coil. Each outdoor air coil shall be factory leak tested with high-pressure air under water.
- B. B. [Outdoor air coils shall be protected from incidental contact to coil fins by a coil guard. Coil guard shall be constructed of cross wire welded steel with PVC coating]

- C. CFan motors shall be an ECM, Electronically Commutated Motor for proportional control. The unit controller shall proportionally control the speed of the condenser fan motors to maintain proper head pressure of the refrigerant circuit from ambient condition of 0~125°F. Mechanical cooling shall be provided to 0° F. The motor shall include thermal overload protection and protect the motor in the case of excessive motor temperatures. The motor shall have phase failure protection and prevent the motor from operation in the event of a loss of phase.
- D. The condenser fan shall be low noise blade design. Fan blade design shall be a dynamic profile for low tip speed. Fan blade shall be of a composite material.
- E. The unit shall have scroll compressors. One of the compressors shall be an inverter compressor providing proportional control. The unit controller shall control the speed of the compressor to maintain the discharge air temperature.
- F. Pressure transducers shall be provided for the suction pressure and head pressure. Temperature sensor shall be provided for the suction temperature and the refrigerant discharge temperature of the compressors. All of the above devices shall be an input to the unit controller and the values be displayed at the unit controller.
- G. Refrigerant circuit shall have a bypass valve between the suction and discharge refrigerant lines for low head pressure compressor starting and increased compressor reliability. When there is a call for mechanical cooling the bypass valve shall open to equalizing the suction and discharge pressures. When pressures are equalized the bypass valve shall close and the compressor shall be allowed to start.
- H. Each circuit shall be dehydrated and factory charged with Refrigerant R-410A and oil.

2.16 Heatpump Heating

- A. The evaporator coil, condenser coil, compressors and refrigerant circuit shall be designed for heatpump operation. The refrigerant circuit shall contain a 4 way reversing valve for the heatpump operation. The outdoor coil shall have an electronic expansion valve to control the refrigerant flow. The unit controller shall modulate the expansion valve to maintain compressor operation within the compressor operational envelope.
- B. The refrigerant system shall have a pump-down cycle.

- C. The unit shall have a natural gas furnace for hybrid heating. When the heatpump operation cannot maintain the discharge air temperature setpoint the natural gas furnace shall temper the airstream to the discharge air temperature setpoint.
- D. The unit shall have an electric resistance heating coil for auxiliary heating. When the heatpump operation cannot maintain the discharge air temperature setpoint the electric heating coil shall temper the airstream to the discharge air temperature setpoint.

2.17 Roof Curb

- A. A prefabricated 14-gauge galvanized steel, mounting curb shall be provided for field assembly on the roof decking prior to unit shipment. The roof curb shall be a full perimeter type with complete perimeter support of the air handling section and condensing section. The curb shall be a minimum of 14" high and include a nominal 2" x 4" wood nailing strip. Gasket shall be provided for field mounting between the unit base and roof curb.

2.18 Electrical

- A. Unit wiring shall comply with NEC requirements and with all applicable UL standards. All electrical components shall be UL recognized where applicable. All wiring and electrical components provided with the unit shall be number and color-coded and labeled according to the electrical diagram provided for easy identification. The unit shall be provided with a factory wired weatherproof control panel. Unit shall have a single point power terminal block for main power connection. A terminal board shall be provided for low voltage control wiring. Branch short circuit protection, 115-volt control circuit transformer and fuse, system switches, and a high temperature sensor shall also be provided with the unit. Each compressor and condenser fan motor shall be furnished with contactors and inherent thermal overload protection. Supply fan motors shall have contactors and external overload protection. Knockouts shall be provided in the bottom of the main control panels for field wiring entrance. A GFI receptacle shall be unit mounted that is field powered.
- B. A single non-fused disconnect switch shall be provided for disconnecting electrical power at the unit. Disconnect switches shall be mounted internally to the control panel and operated by an externally mounted handle.

2.19 Controls

- A. Provide a complete integrated microprocessor based Direct Digital Control (DDC) system to control all unit functions including temperature control, scheduling, monitoring, unit safety protection, including compressor minimum run and minimum off times, and diagnostics. This system shall consist of all required temperature sensors, pressure sensors, controller and keypad/display operator interface. All MCBs and sensors shall be factory mounted, wired and tested.
- B. The stand-alone DDC controllers shall not be dependent on communications with any on-site or remote PC or master control panel for proper unit operation. The microprocessor shall maintain existing set points and operate stand alone if the unit loses either direct connect or network communications. The microprocessor memory shall be protected from voltage fluctuations as well as any extended power failures. All factory and user set schedules and control points shall be maintained in nonvolatile memory. No settings shall be lost, even during extended power shutdowns.
- C. The DDC control system shall permit starting and stopping of the unit locally or remotely. The control system shall be capable of providing a remote alarm indication. The unit control system shall provide for outside air damper actuation, emergency shutdown, remote heat enable/disable, remote cool enable/disable, heat indication, cool indication, and fan operation.
- D. All digital inputs and outputs shall be protected against damage from transients or incorrect voltages. All field wiring shall be terminated at a separate, clearly marked terminal strip.
- E. The DDC controller shall have a built-in time schedule. The schedule shall be programmable from the unit keypad interface. The schedule shall be maintained in nonvolatile memory to insure that it is not lost during a power failure. There shall be one start/stop per day and a separate holiday schedule. The controller shall accept up to sixteen holidays each with up to a 5-day duration. Each unit shall also have the ability to accept a time schedule via BAS network communications.

Engineering Specifications

- F. The keypad interface shall allow convenient navigation and access to all control functions. The unit keypad/display character format shall be 4 lines x 20 characters. All control settings shall be password protected against unauthorized changes. For ease of service, the display format shall be English language readout. Coded formats with look-up tables will not be accepted. The user interaction with the display shall provide the following information as a minimum:
1. Return air temperature
 2. Discharge air temperature
 3. Outdoor air temperature
 4. Space air temp
 5. Outdoor enthalpy, high/low
 6. Compressor suction temperature and pressure
 7. Compressor head pressure and temperature
 8. Expansion valve position
 9. Condenser fan speed
 10. Inverter compressor speed
 11. Dirty filter indication
 12. Airflow verification
 13. Cooling status
 14. Control temperature (Changeover)
 15. VAV box output status
 16. Cooling status/capacity
 17. Unit status
 18. All time schedules
 19. Active alarms w/time and date
 20. Previous alarms with time and date
 21. Optimal start
 22. Supply fan [and exhaust fan] speed
 23. System operating hours
 - a. Fan
 - b. Exhaust fan
 - c. Cooling
 - d. Individual compressor
 - e. Heating
 - f. Economizer
 - g. Tenant override
- G. The user interaction with the keypad shall provide the following:
1. Controls mode
 - a. Off manual
 - b. Auto
 - c. Heat/cool
 - d. Cool only
 - e. Heat only
 - f. Fan only
 2. Occupancy mode
 - a. Auto
 - b. Occupied
 - c. Unoccupied
 - d. Tenant override
 3. Unit operation changeover control
 - a. Return air temperature
 - b. Space temperature
 - c. Network signal
 4. Cooling and heating change-over temperature with deadband
 5. Cooling discharge air temperature (DAT)
 6. Supply reset options
 - a. Return air temperature
 - b. Outdoor air temperature
 - c. Space temperature
 - d. Airflow (VAV)
 - e. Network signal
 - f. External (0-10 vdc)
 - g. External (0-20mA)
 7. Temperature alarm limits
 - a. High supply air temperature
 - b. Low supply air temperature
 - c. High return air temperature
 8. Lockout control for compressors
 9. Compressor interstage timers
 10. Night setback and setup space temperature
 11. Building static pressure

12. Economizer changeover
 - a. Enthalpy
 - b. Drybulb temperature
13. Current time and date
14. Tenant override time
15. Occupied/unoccupied time schedule
16. One event schedule
17. Holiday dates and duration
18. Adjustable set points
19. Service mode
 - a. Timers normal (all time delays normal)
 - b. Timers fast (all time delays 20 sec)
- H. If the unit is to be programmed with a night setback or setup function, an optional space sensor shall be provided. Space sensors shall be available to support field selectable features. Sensor options shall include:
 1. Zone sensor with tenant override switch
 2. Zone sensor with tenant override switch plus heating and cooling set point adjustment. (Space Comfort Control systems only)
- I. To increase the efficiency of the cooling system the DDC controller shall include a discharge air temperature reset program for part load operating conditions. The discharge air temperature shall be controlled between a minimum and a maximum discharge air temperature (DAT) based on one of the following inputs:
 1. Airflow
 2. Outside air temperature
 3. Space Temperature
 4. Return air temperature
 5. External signal of 1-5 VDC
 6. External signal of 0-20 mA
 7. Network signal

Daikin McQuay Training and Development

Now that you have made an investment in modern, efficient Daikin McQuay equipment, its care should be a high priority. For training information on all Daikin McQuay HVAC products, please visit us at www.DaikinMcQuay.com and click on training, or call 540-248-9646 and ask for the Training Department.

Warranty

All Daikin McQuay equipment is sold pursuant to its standard terms and conditions of sale, including Limited Product Warranty. Consult your local Daikin McQuay Representative for warranty details. Refer to Form 933-430285Y. To find your local Daikin McQuay Representative, go to www.DaikinMcQuay.com.

Aftermarket Services

To find your local parts office, visit www.DaikinMcQuay.com or call 800-37PARTS (800-377-2787). To find your local service office, visit www.DaikinMcQuay.com or call 800-432-1342.

This document contains the most current product information as of this printing. For the most up-to-date product information, please go to www.DaikinMcQuay.com.

Products Manufactured in an ISO Certified Facility.

